

300 / 350 grilles



metric sizes



MRI compatible



humid areas



prevents corrosion

H

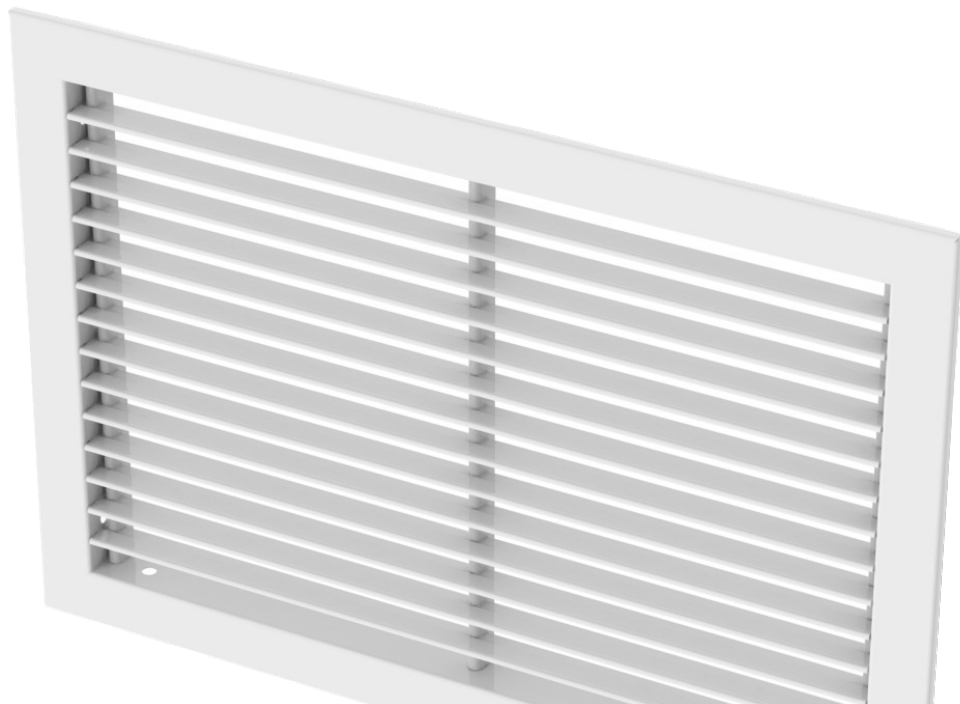

Table of Contents

300/350 grille products

300/350 Grille Products..... H4

overview

Application Icons Key..... H3
Overview..... H8

supply grilles

Supply Grilles H9

³/₄" Spacing - Steel..... H9

 301 (RL / RS) - Single Deflection..... H9

 300 (RL / RS) - Double Deflection H9

 Dimensions..... H10

³/₄" Spacing - Aluminum H11

 301 (FL / FS) - Single Deflection H11

 300 (FL / FS) - Double Deflection H11

 Dimensions..... H12

³/₄" Spacing - Stainless Steel H13

 301 (RL-SS / RS-SS) - Single Deflection..... H13

 300 (RL-SS / RS-SS) - Double Deflection H13

 Dimensions..... H14

¹/₂" Spacing - Steel..... H15

 301 (RL-HD / RS-HD) - Single Deflection H15

 300 (RL-HD / RS-HD) - Double Deflection H15

 Dimensions..... H16

 Performance Data..... H17

 Performance Notes..... H22

 Horizontal Deflection (Spread) H23

³/₄" Spacing - Aluminum H24

 R-301F - Single Deflection H24

 R-300F - Double Deflection H24

 Dimensions..... H25

 Performance Data..... H26

return grilles

Return Grilles..... H27

³/₄" Spacing - Steel..... H27

 350 (RL / RS) - 35° Deflection H27

 350 (ZRL / ZRS) - 0° Deflection H27

 Dimensions..... H28

³/₄" Spacing - Aluminum H29

 350 (FL / FS) - 35° Deflection H29

 350 (ZFL / ZFS) - 0° Deflection H29

 Dimensions..... H30

³/₄" Spacing - Stainless Steel H31

 350 (RL-SS / RS-SS) - 45° Deflection H31

 Dimensions..... H32

¹/₂" Spacing - Steel..... H33

 355 (RL / RS) - 35° Deflection H33

 355 (ZRL / ZRS) - 0° Deflection H33

 Dimensions..... H34

¹/₂" Spacing - Aluminum H35

 355 (FL / FS) - 35° Deflection H35

 355 (ZFL / ZFS) - 0° Deflection H35

 Dimensions..... H36

 Performance Data..... H37

 350R, 350F and 350R-SS H37

 350ZR and 350ZF H39

 355R and 355F H41

 355ZR and 355ZF H43

filter return grilles

Filter Return Grilles	H45
Steel, Aluminum and Stainless Steel	H45
350 (RLF / RSF) / 350 (FLF / FSF) / 355 (RLF / RSF) / 355 (FLF / FSF) / 350 (RLF-SS / RSF-SS)	H45

options & accessories

Option & Accessories	H46
Border Types	H47
Accessories	H47
Oversize Grille Construction	H48
Screw Hole Location Chart	H49



APPLICATION ICONS KEY



for use in MRI environments & will not significantly affect the diagnostic information

MRI compatible



for use in corrosive environment applications

prevents corrosion



especially suited to work in areas where high humidity may become a factor

humid areas



Diffuser module sizes are hard metric & inlets are soft. Metric linear and grille products are converted to the nearest 1/4" for ordering. Contact us for more information.

metric sizes

pages: H8-H23

supply grilles



301 (RL / RS)

STEEL SINGLE DEFLECTION GRILLES

- Available in 3/4" blade spacing
- Individually adjustable blades
- Blades parallel to the long or short dimension
- Standard finish is #26 white

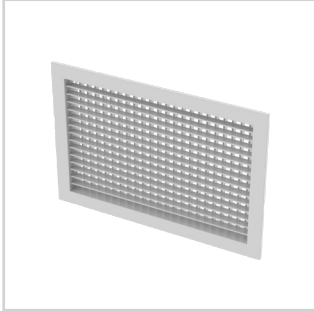

300 (RL / RS)

STEEL DOUBLE DEFLECTION GRILLES

- Available in 3/4" blade spacing
- Individually adjustable blades
- Blades parallel to the long & short dimension
- Standard finish is #26 white



301 (FL / FS)

ALUMINUM SINGLE DEFLECTION GRILLES

- Available in 3/4" blade spacing
- Individually adjustable blades
- Blades parallel to the long or short dimension
- Standard finish is #26 white

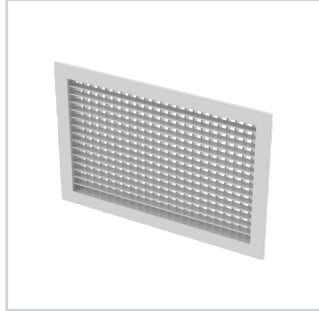

300 (FL / FS)

ALUMINUM DOUBLE DEFLECTION GRILLES

- Available in 3/4" blade spacing
- Individually adjustable blades
- Blades parallel to the long & short dimension
- Standard finish is #26 white

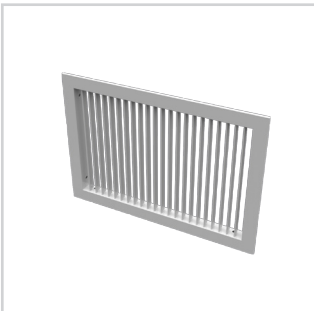

301 (RL-SS / RS-SS)

STAINLESS STEEL SINGLE DEFLECTION GRILLES

- Available in 3/4" blade spacing
- Individually adjustable blades
- Blades parallel to the long or short dimension
- Works well in corrosive environments
- Standard finish is #04 mill

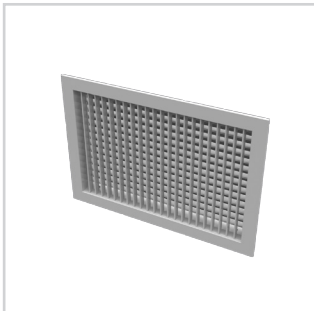

300 (RL-SS / RS-SS)

STAINLESS STEEL DOUBLE DEFLECTION GRILLES

- Available in 3/4" blade spacing
- Individually adjustable blades
- Blades parallel to the long & short dimension
- Works well in corrosive environments
- Standard finish is #04 mill



301 (RL-HD / RS-HD)

HEAVY DUTY STEEL SINGLE DEFLECTION GRILLES

- Available in 1/2" blade spacing
- Individually adjustable blades
- Blades parallel to the long or short dimension
- Works well in areas subject to abuse
- Standard finish is #26 white

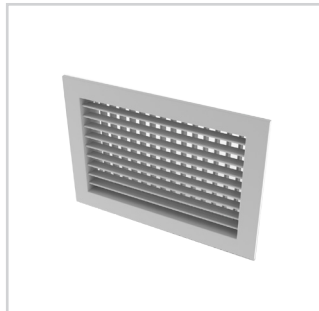

300 (RL-HD / RS-HD)

HEAVY DUTY STEEL DOUBLE DEFLECTION GRILLES

- Available in 1/2" blade spacing
- Individually adjustable blades
- Blades parallel to the long & short dimension
- Works well in areas subject to abuse
- Standard finish is #26 white

pages: H24-H26

round supply grilles



R-301F

ALUMINUM SINGLE DEFLECTION GRILLES

- Available in 3/4" blade spacing
- Individually adjustable blades
- Blades parallel to the long or short dimension
- Standard finish is #26 white
- Optional mounting bracket and damper available



R-300F

ALUMINUM DOUBLE DEFLECTION GRILLES

- Available in 3/4" blade spacing
- Individually adjustable blades
- Blades parallel to the long & short dimension
- Standard finish is #26 white
- Optional mounting bracket and damper available

pages: H23-H40

return grilles



350 (RL / RS)



350 (ZRL / ZRS)



350 (FL / FS)



350 (ZFL / ZFS)



350 (RL-SS / RS-SS)



355 (RL / RS)



355 (ZRL / ZRS)

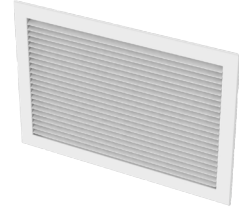

355 (FL / FS)

RETURN GRILLES

- Available in 3/4" or 1/2" blade spacing
- 35°, 45° and 0° deflection models to choose from
- Available in steel, aluminum and stainless steel
- Blades parallel to the long or short dimension
- Finishes are either #26 white or #04 mill



355 (ZFL / ZFS)

page: H41

filter return grilles

			
350 (RLF / RSF)	350 (FLF / FSF)	355 (RLF / RSF)	355 (FLF / FSF)
<p>RETURN FILTER GRILLES</p> <ul style="list-style-type: none"> • Available in ¾" blade spacing • 35° deflection blades • Available in steel • Accommodates 1" or 2" thick filters • Standard finish is #26 white 	<p>RETURN FILTER GRILLES</p> <ul style="list-style-type: none"> • Available in ¾" blade spacing • 35° deflection blades • Available in aluminum • Accommodates 1" or 2" thick filters • Standard finish is #26 white 	<p>RETURN FILTER GRILLES</p> <ul style="list-style-type: none"> • Available in ½" blade spacing • 35° deflection blades • Available in steel • Accommodates 1" or 2" thick filters • Standard finish is #26 white 	<p>RETURN FILTER GRILLES</p> <ul style="list-style-type: none"> • Available in ½" blade spacing • 35° deflection blades • Available in aluminum • Accommodates 1" or 2" thick filters • Standard finish is #26 white



350 (RLF-SS / RSF-SS)

- RETURN FILTER GRILLES**
- Available in ¾" blade spacing
 - 45° deflection blades
 - Available in stainless steel
 - Accommodates 1" or 2" thick filters
 - Standard finish is #04 mill

Overview

The Titus 300 / 350 series of louvered supply and return grilles are the industry standard for high quality, competitively priced grilles. The series is available in steel, aluminum and stainless steel material to meet any job application. The 300 series supply grilles feature adjustable louvered blades in single or double deflection with 3/4" blade spacing. For industrial and institutional applications, the 300 series are available in a heavy duty "HD" design that includes heavy gauge frame and blades. The 350 series return grilles are available in 3/4" or 1/2" blade spacing and 0 degree or 35 degree deflection to provide maximum versatility for return air applications. The 350 series also include an option for a factory installed filter rack to accommodate 1" or 2" thick filters. Optional opposed blade dampers are available for the 300 / 350 series in steel, aluminum and stainless steel material and are factory installed.

- High quality, competitively priced grilles
- Defines the standard for the industry
- Available in steel, aluminum, or 304 stainless steel
- Available in supply, return, or filter return models
- Standard supply grilles available with 3/4" blade spacing
- Return grilles available with 3/4" or 1/2" blade spacing
- Front blades available parallel to the long or short dimension

300 / 350 OVERVIEW AT A GLANCE

Function	Description		Steel Border		Aluminum Border		304 Stainless Steel	
	Deflection	Blade Spacing	Long Front Blades	Short Front Blades	Long Front Blades	Short Front Blades	Long Front Blades	Short Front Blades
Supply	Single	3/4"	301RL	301RS	301FL	301FS	301RL-SS	301RS-SS
	Double	3/4"	300RL	300RS	300FL	300FS	300RL-SS	300RS-SS
Heavy Duty Supply	Single	1/2"	301RLHD	301RSHD	—	—	—	—
	Double	1/2" front 3/4" rear	300RLHD	300RSHD	—	—	—	—
Return	35° Fixed	3/4"	350RL	350RS	350FL	350FS	350RL-SS	350RS-SS
	0° Fixed	3/4"	350ZRL	350ZRS	350ZFL	350ZFS	—	—
	35° Fixed	1/2"	355RL	355RS	355FL	355FS	—	—
	0° Fixed	1/2"	355ZRL	355ZRS	355ZFL	355ZFS	—	—
Filter Return	35° Fixed	3/4"	350RLF	350RSF	350FLF	350FSF	350RLF-SS	350RSF-SS
	35° Fixed	1/2"	355RLF	355RSF	355FLF	355FSF	—	—

Available Material Types	Model							
	Supply				Return			
	301	300	301HD	300HD	350	355	350Z	355Z
A	•	•			•	•	•	•
S	•	•	•	•	•	•	•	•
SS	•	•			•			

Note: A = Aluminum Border and Blades, S = Steel, SS = 304 Stainless Steel. Some aluminum and stainless steel models may be constructed of all nonmagnetic components (no plastics) to meet MRI requirements. Consult your Titus representative for specific details. See individual model information for construction details. Titus reserves the right to make product improvements on a continual basis. As products are updated, new submittal sheets are published. Your Titus representative can provide you with updated technical information on all products.

300 / 350 Supply Grilles

300 / 350 grilles

301 / 300 (RL / RS)

301RS

- 3/4" blade spacing
- Single deflection
- Individually adjustable blades
- Blades parallel to the short dimension

301RL

- Same as 301RS with blades parallel to the long dimension

300RS

- 3/4" blade spacing
- Double deflection
- Individually adjustable blades
- Front blades parallel to the short dimension

300RL

- Same as 300RS with front blades parallel to the long dimension



301RL

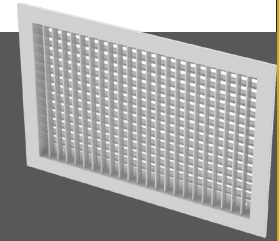

300RS



metric sizes

AVAILABLE MODELS:

Single Deflection Models

301RL
301RS

Double Deflection Models

300RL
300RS

FINISH

Standard Finish - #26 White

OVERVIEW

3/4" Blade Spacing / Steel

Titus' 300 / 350 Series supply grilles define the standard for the industry. With high quality and competitive pricing these grilles form the backbone of a standard offering that will meet any application requirements.

PRODUCTS INCLUDE

- Material: Roll-formed Steel
- Welded Border
- Available Border Types:
 - #1 - Surface Mount
- Countersunk Screw Holes
- #8 x 1 1/4" Long Phillips Flat Head Sheet Metal Screws, Painted White
- Optional Steel-Opposed Blade Damper



See website for Specifications

DIMENSIONS

Redefine your comfort zone™ | www.titus-hvac.com

301 / 300 (RL / RS) DIMENSIONS

Single Deflection Models 301RL / RS - Border Type 1

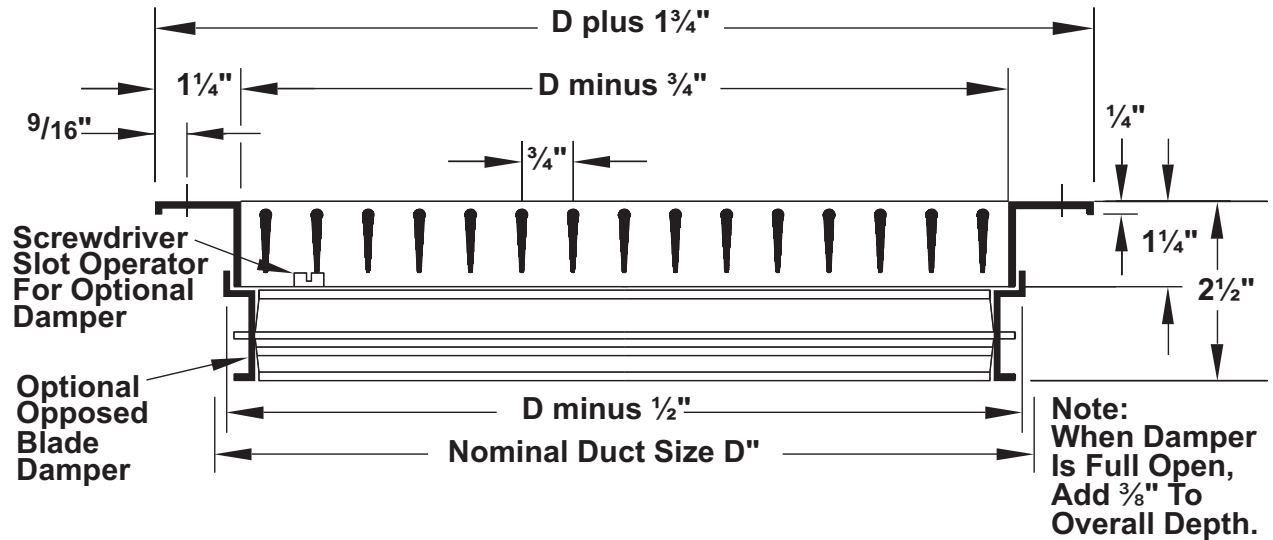

Available sizes (D" x D") are 6 x 4 inches through 48 x 48 inches in 1" increments
Odd and fractional sizes are available at additional cost

Double Deflection Models 300RL / RS - Border Type 1

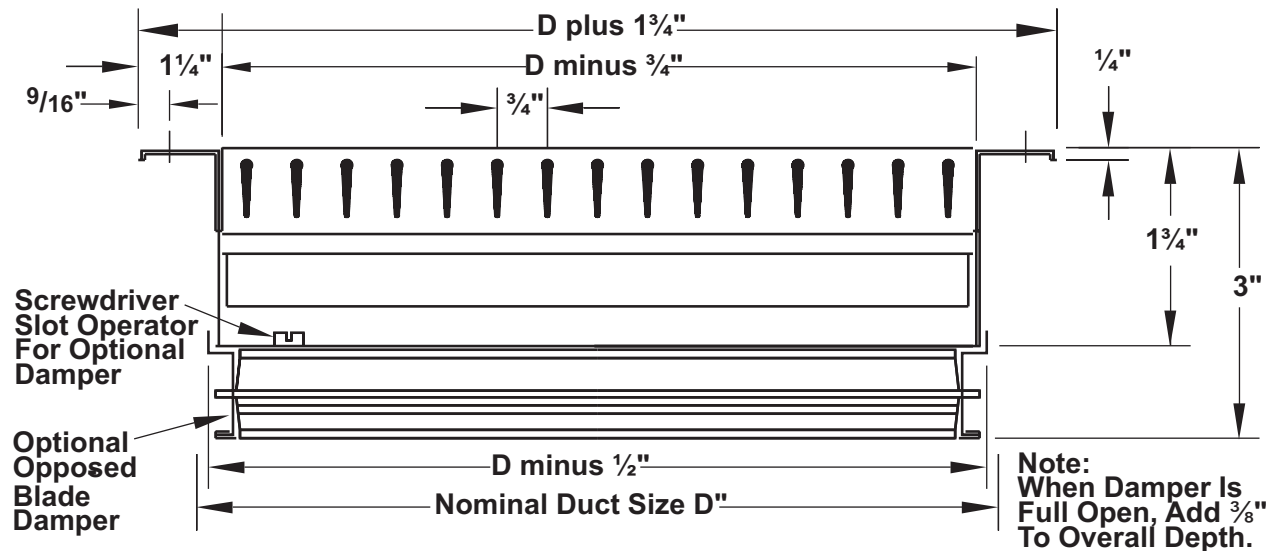

Available sizes (D" x D") are 6 x 4 inches through 48 x 48 inches in 1" increments
Odd and fractional sizes are available at additional cost

H

DIMENSIONS

H10

301 / 300 (FL / FS)

301FS

- Great for areas with high humidity or subject to moisture
- 3/4" blade spacing
- Single deflection
- Individually adjustable blades
- Blades parallel to the short dimension

301FL

- Same as 301FS with blades parallel to the long dimension

300FS

- Great for areas with high humidity or subject to moisture
- 3/4" blade spacing
- Double deflection
- Individually adjustable blades
- Front blades parallel to the short dimension



301FL

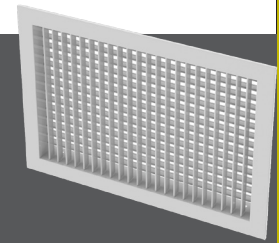

300FS

300FL

- Same as 300FS with front blades parallel to the long dimension



metric sizes



humid areas

AVAILABLE MODELS:

Single Deflection Models

301FL
301FS

Double Deflection Models

300FL
300FS

FINISH

Standard Finish - #26 White

OVERVIEW

3/4" Blade Spacing / Aluminum

Titus' 300 / 350 Series supply grilles define the standard for the industry. With high quality and competitive pricing these grilles form the backbone of a standard offering that will meet any application requirements.

PRODUCTS INCLUDE

- Material: Roll-formed Aluminum Border and Blades on sizes up to 24 x 24 inches. Extruded Aluminum Blades for Larger Sizes.
- Welded Border
- Available Border Types:
 - #1 - Surface Mount
- Countersunk Screw Holes
- #8 x 1 1/4" Long Phillips Flat Head Sheet Metal Screws, Painted White
- Optional Steel or Aluminum Opposed-Blade Damper



See website for Specifications

DIMENSIONS

Redefine your comfort zone™ | www.titus-hvac.com

301 / 300 (FL / FS) DIMENSIONS

Single Deflection Models 301FL / FS - Border Type 1

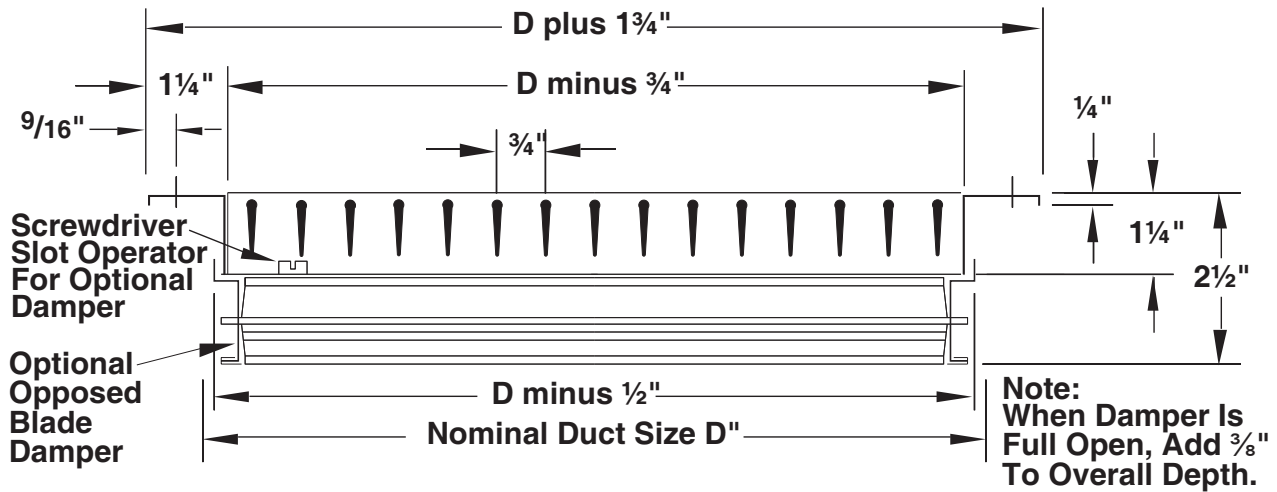

Available sizes (D" x D") are 6 x 4 inches through 48 x 48 inches in 1" increments
Odd and fractional sizes are available at additional cost

Double Deflection Models 300FL / FS - Border Type 1

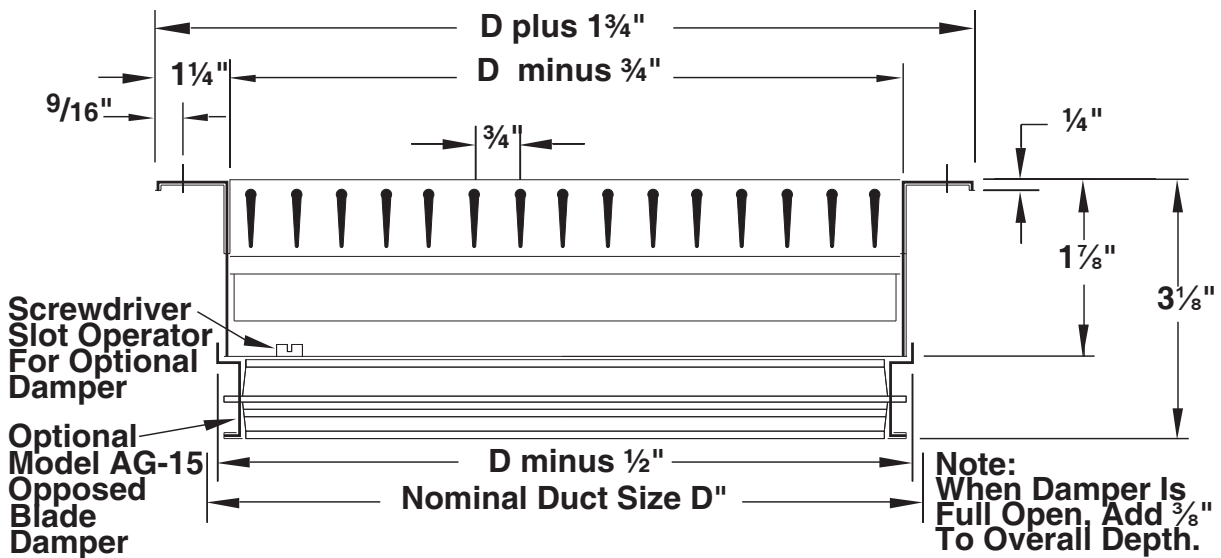

Available sizes (D" x D") are 6 x 4 inches through 48 x 48 inches in 1" increments
Odd and fractional sizes are available at additional cost

DIMENSIONS

301 / 300 (RL-SS / RS-SS)

301RS-SS

- Great for use in corrosive environments
- ¾" blade spacing
- Single deflection
- Individually adjustable blades
- Blades parallel to the short dimension
- Available in 316 Stainless Steel

301RL-SS

- Same as 301RS-SS with blades parallel to the long dimension

300RS-SS

- Great for use in corrosive environments
- ¾" blade spacing
- Double deflection
- Individually adjustable blades
- Front blades parallel to the short dimension



301RL-SS

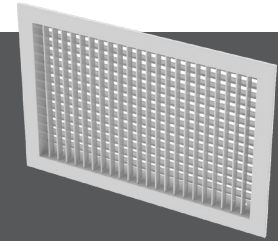

300RS-SS

- Available in 316 Stainless Steel

300RL-SS

- Same as 300RS-SS with front blades parallel to the long dimension



metric sizes



prevents corrosion

AVAILABLE MODELS:

Single Deflection Models

301RL-SS
301RS-SS

Double Deflection Models

300RL-SS
300RS-SS

FINISH

Standard Finish - #04 Mill

OVERVIEW

¾" Blade Spacing / Stainless Steel

Titus' 300 / 350 Series supply grilles define the standard for the industry. With high quality and competitive pricing these grilles form the backbone of a standard offering that will meet any application requirements.

PRODUCTS INCLUDE

- Material: 304 Stainless Steel Border and Blades
- Welded Border
- Available Border Types:
 - #1 - Surface Mount
- Countersunk Screw Holes
- #8 x 1¼" Long Phillips Flat Stainless Steel Head Sheet Metal Screws
- Optional 304 Stainless Steel Opposed-Blade Damper



See website for Specifications

DIMENSIONS

Redefine your comfort zone™ | www.titus-hvac.com

301 / 300 (RL-SS / RS-SS) DIMENSIONS

Single Deflection Models 301RL-SS / RS-SS - Border Type 1

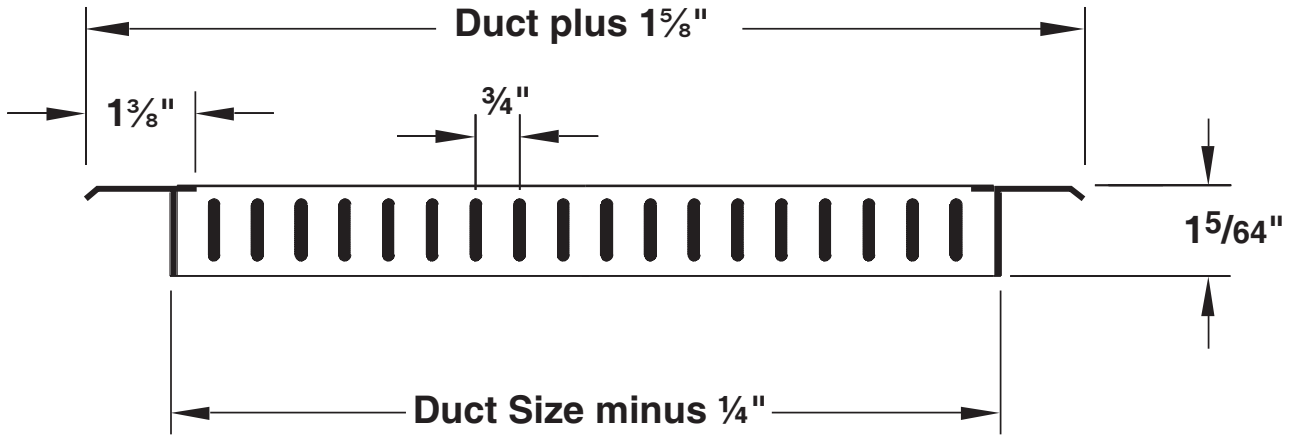

Available sizes (D" x D") are 6 x 4 inches through 48 x 48 inches in 2" increments
Odd and fractional sizes are available at additional cost

Double Deflection Models 300RL-SS / RS-SS - Border Type 1

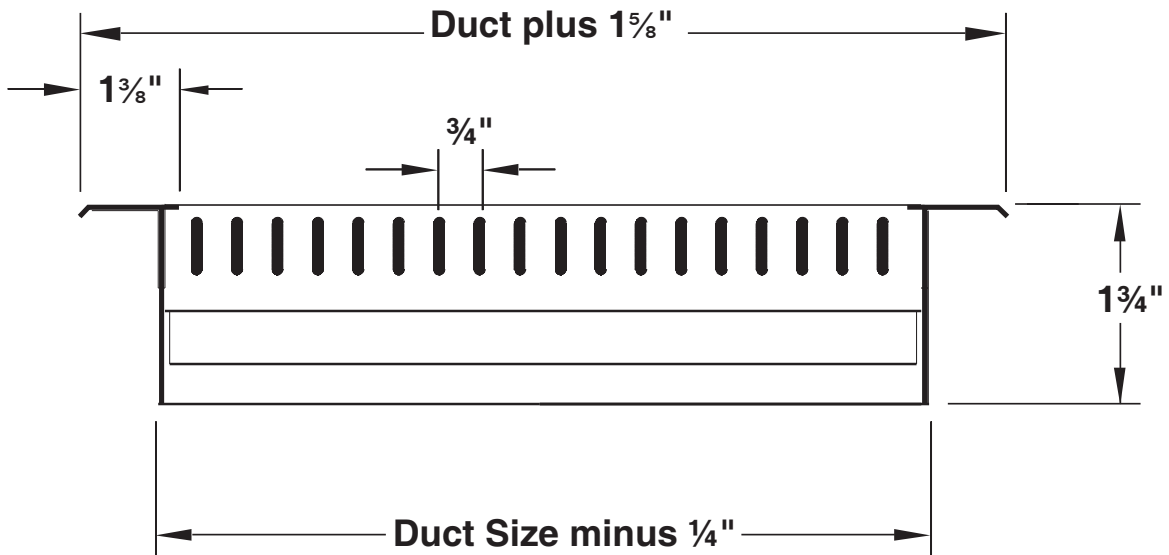

Available sizes (D" x D") are 6 x 4 inches through 48 x 48 inches in 2" increments
Odd and fractional sizes are available at additional cost

DIMENSIONS

301 / 300 (RL-HD / RS-HD)

301RS-HD

- Great for use in areas subject to abuse
- ½" blade spacing
- Single deflection
- Individually adjustable blades
- Blades parallel to the short dimension
- 14-gauge blades, 18-gauge borders

301RL-HD

- Same as 301RS-HD with blades parallel to the long dimension

300RS-HD

- Great for use in areas subject to abuse
- ½" blade spacing
- Double deflection
- Individually adjustable blades
- Front blades parallel to the short dimension



301RL-HD

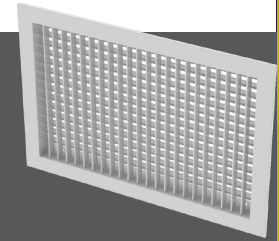

300RS-HD

- 14-gauge blades, 18-gauge borders

300RL-HD

- Same as 300RS-HD with front blades parallel to the long dimension



metric sizes

AVAILABLE MODELS:

Single Deflection Models

301RL-HD
301RS-HD

Double Deflection Models

300RL-HD
300RS-HD

FINISH

Standard Finish - #26 White

OVERVIEW

½" Blade Spacing / Steel

Titus' 300 / 350 Series supply grilles define the standard for the industry. With high quality and competitive pricing these grilles form the backbone of a standard offering that will meet any application requirements.

PRODUCTS INCLUDE

- Material: Steel
- Welded Border
- Available Border Types:
 - #1 - Surface Mount
- Countersunk Screw Holes
- #8 x 1¼" Long Phillips Flat Head Sheet Metal Screws, Painted White
- Optional Steel Opposed-Blade Damper



See website for Specifications

DIMENSIONS

Redefine your comfort zone™ | www.titus-hvac.com

301 / 300 (RL-HD / RS-HD) DIMENSIONS

Single Deflection Models 301RL-HD / RS-HD - Border Type 1

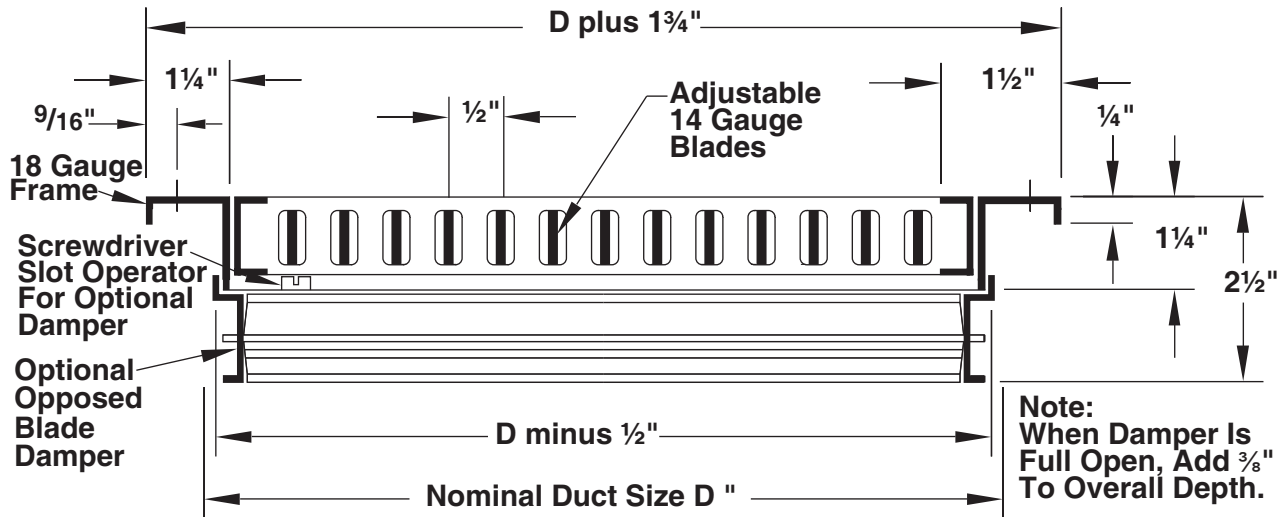

Available sizes (D" x D") are 6 x 4 inches through 48 x 48 inches in 1" increments
Odd and fractional sizes are available at additional cost

Double Deflection Models 300RL-HD / RS-HD - Border Type 1

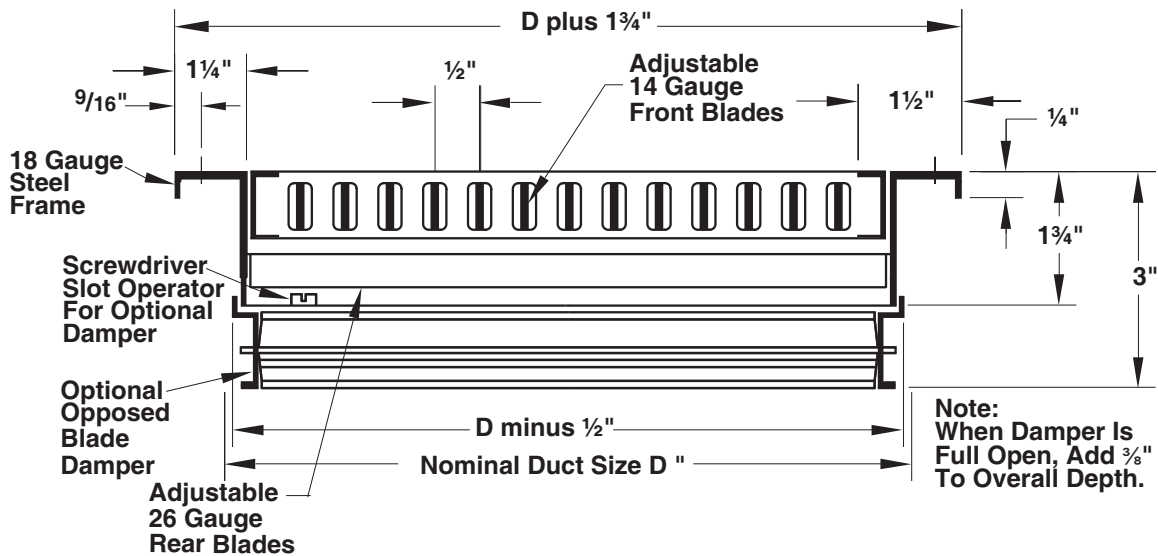

Available sizes (D" x D") are 6 x 4 inches through 48 x 48 inches in 1" increments
Odd and fractional sizes are available at additional cost

DIMENSIONS

PERFORMANCE DATA

300 / 350 grilles

MODELS: 300R, 300F, 300R-SS, 300R-HD, 301R, 301F, 301R-SS AND 301R-HD
PERFORMANCE BASED ON NOMINAL SIZES SHOWN IN BOLD

Nom. Duct Size (in.)	Nom. Duct Area (ft ²)	Core Area (ft ²)	Core Vel. Vel. Press.	NC-20				NC-30		NC-40		
				300	400	500	600	700	800	1000	1200	1400
				0°	22.5°	45°	0°	22.5°	45°	0°	22.5°	45°
6x6	0.25	0.19	cfm	57	76	95	114	133	152	190	228	266
			NC	-	-	-	15	20	24	31	36	41
			Throw (ft)	5-7-14	7-10-16	8-12-18	10-14-20	12-15-21	13-16-23	15-18-25	16-20-28	17-21-30
			45°	2-3-6	3-4-7	4-6-8	4-6-9	5-7-10	6-7-10	7-8-11	7-9-12	8-10-13
8x6	0.33	0.26	cfm	78	104	130	156	182	208	260	312	364
			NC	-	-	11	17	21	25	32	38	42
			Throw (ft)	5-9-16	8-12-19	10-15-21	12-16-23	14-18-25	15-19-27	17-21-30	19-23-32	20-25-35
			45°	2-4-7	3-5-8	4-7-9	5-7-10	6-8-11	7-8-12	8-9-13	8-10-15	9-11-16
10x6	0.42	0.34	cfm	102	136	170	204	238	272	340	408	476
			NC	-	-	12	18	23	27	33	39	43
			Throw (ft)	6-10-19	9-13-21	11-17-24	13-19-26	16-20-28	18-21-30	20-24-34	21-26-37	23-28-40
			45°	3-4-8	4-6-10	5-7-11	6-8-12	7-9-13	8-10-14	9-11-15	10-12-17	10-13-18
8x8	0.44	0.37	cfm	111	148	185	222	259	296	370	444	518
			NC	-	-	13	18	23	27	34	39	44
			Throw (ft)	6-10-19	9-14-22	12-17-25	14-19-27	16-21-30	18-22-32	20-25-35	22-27-39	24-30-42
			45°	3-5-9	4-6-10	5-8-11	6-9-12	7-9-13	8-10-14	9-11-16	10-12-17	11-13-19
12x6	0.50	0.41	cfm	123	164	205	246	287	328	410	492	574
			NC	-	-	13	19	23	27	34	39	44
			Throw (ft)	7-11-20	10-15-24	12-18-26	15-20-29	17-22-31	19-24-33	21-26-37	24-29-41	25-31-44
			45°	3-5-9	4-7-11	5-8-12	7-9-13	8-10-14	9-11-15	10-12-17	11-13-18	11-14-20
14x6	0.58	0.48	cfm	144	192	240	288	336	384	480	576	672
			NC	-	-	14	19	24	28	35	40	45
			Throw (ft)	7-12-22	11-16-25	13-20-28	16-22-31	18-24-34	21-25-36	23-28-40	25-31-44	28-34-48
			45°	3-5-10	4-7-11	5-8-12	7-10-14	8-11-15	9-11-16	10-13-18	11-14-20	12-15-21
16x6 12x8	0.67	0.57	cfm	171	228	285	342	399	456	570	684	798
			NC	-	-	15	20	25	29	35	41	45
			Throw (ft)	8-13-24	11-17-28	14-22-31	17-24-34	20-26-37	23-28-39	25-31-44	28-34-48	30-37-52
			45°	4-6-11	5-8-12	6-10-14	8-11-15	9-12-17	10-12-18	11-14-20	12-15-22	13-17-23
10x10	0.69	0.59	cfm	177	236	295	354	413	472	590	708	826
			NC	-	-	15	20	25	29	35	41	46
			Throw (ft)	8-13-24	12-18-28	15-22-32	18-24-35	20-26-37	23-28-40	26-32-45	28-35-49	31-37-53
			45°	4-6-11	5-8-13	7-10-14	8-11-16	9-12-17	10-13-18	12-14-20	13-16-22	14-17-24
18x6	0.75	0.63	cfm	189	252	315	378	441	504	630	756	882
			NC	-	-	15	20	25	29	36	41	46
			Throw (ft)	8-14-25	12-18-29	15-23-33	18-25-36	21-27-39	24-29-41	27-33-46	29-36-51	32-39-55
			45°	4-6-11	5-8-13	7-10-15	8-11-16	9-12-17	11-13-19	12-15-21	13-16-23	14-17-25
20x6 12x10	0.83	0.72	cfm	216	288	360	432	504	576	720	864	1008
			NC	-	-	16	21	26	30	36	42	46
			Throw (ft)	9-15-27	13-19-31	16-24-35	19-27-38	23-29-41	25-31-44	28-35-49	31-38-54	34-41-58
			45°	4-7-12	6-9-14	7-11-16	9-12-17	10-13-19	11-14-20	13-16-22	14-17-24	15-19-26
22x6	0.92	0.77	cfm	231	308	385	462	539	616	770	924	1078
			NC	-	-	16	21	26	30	37	42	47
			Throw (ft)	9-15-28	13-20-32	17-25-36	20-28-40	23-30-43	26-32-46	29-36-51	32-40-56	35-43-60
			45°	4-7-13	6-9-15	8-11-16	9-13-18	11-14-19	12-15-21	13-16-23	15-18-25	16-19-27
24x6 18x8 12x12	1.00	0.88	cfm	264	352	440	528	616	704	880	1056	1232
			NC	-	-	16	22	26	30	37	43	47
			Throw (ft)	10-16-30	14-21-34	18-27-39	21-30-42	25-32-46	28-34-49	31-39-55	34-42-60	37-46-65
			45°	4-7-13	6-10-16	8-12-17	10-13-19	11-15-21	13-16-22	14-17-25	16-19-27	17-21-29
30x6 18x10	1.25	1.11	cfm	333	444	555	666	777	888	1110	1332	1554
			NC	-	11	17	23	27	31	38	44	48
			Throw (ft)	11-18-34	16-24-39	20-30-43	24-34-47	28-36-51	32-39-55	35-43-61	39-47-67	42-51-72
			45°	5-8-15	7-11-17	9-14-19	11-15-21	13-16-23	14-17-25	16-19-28	17-21-30	19-23-33

Performance notes appear at end of table



PERFORMANCE DATA

300 / 350 grilles

MODELS: 300R, 300F, 300R-SS, 300R-HD, 301R, 301F, 301R-SS AND 301R-HD
PERFORMANCE BASED ON NOMINAL SIZES SHOWN IN BOLD

Nom. Duct Size (in.)	Nom. Duct Area (ft²)	Core Area (ft²)	Core Vel. Vel. Press.	NC-20			NC-30		NC-40		NC-50	
				300	400	500	600	700	800	1000	1200	1400
				0.006	0.010	0.016	0.022	0.031	0.040	0.062	0.090	0.122
14x14	1.36	1.22	0°	0.016	0.029	0.046	0.066	0.090	0.117	0.183	0.263	0.358
			22.5°	0.018	0.033	0.051	0.074	0.100	0.131	0.204	0.294	0.401
			45°	0.028	0.049	0.077	0.111	0.152	0.198	0.309	0.445	0.606
			cfm	366	488	610	732	854	976	1220	1464	1708
36x6 27x8 18x12	1.50	1.35	0°	0.016	0.029	0.046	0.066	0.090	0.117	0.183	0.263	0.358
			22.5°	0.018	0.033	0.051	0.074	0.100	0.131	0.204	0.294	0.401
			45°	0.028	0.049	0.077	0.111	0.152	0.198	0.309	0.445	0.606
			cfm	405	540	675	810	945	1080	1350	1620	1890
22x10	1.53	1.37	0°	0.016	0.029	0.046	0.066	0.090	0.117	0.183	0.263	0.358
			22.5°	0.018	0.033	0.051	0.074	0.100	0.131	0.204	0.294	0.401
			45°	0.028	0.049	0.077	0.111	0.152	0.198	0.309	0.445	0.606
			cfm	411	548	685	822	959	1096	1370	1644	1918
30x8 24x10	1.67	1.49	0°	0.016	0.029	0.046	0.066	0.090	0.117	0.183	0.263	0.358
			22.5°	0.018	0.033	0.051	0.074	0.100	0.131	0.204	0.294	0.401
			45°	0.028	0.049	0.077	0.111	0.152	0.198	0.309	0.445	0.606
			cfm	447	596	745	894	1043	1192	1490	1788	2086
42x6 18x14	1.75	1.59	0°	0.016	0.029	0.046	0.066	0.090	0.117	0.183	0.263	0.358
			22.5°	0.018	0.033	0.051	0.074	0.100	0.131	0.204	0.294	0.401
			45°	0.028	0.049	0.077	0.111	0.152	0.198	0.309	0.445	0.606
			cfm	477	636	795	954	1113	1272	1590	1908	2226
16x16	1.78	1.62	0°	0.016	0.029	0.046	0.066	0.090	0.117	0.183	0.263	0.358
			22.5°	0.018	0.033	0.051	0.074	0.100	0.131	0.204	0.294	0.401
			45°	0.028	0.049	0.077	0.111	0.152	0.198	0.309	0.445	0.606
			cfm	486	648	810	972	1134	1296	1620	1944	2268
48x6 36x8 24x12 18x16	2.00	1.82	0°	0.016	0.029	0.046	0.066	0.090	0.117	0.183	0.263	0.358
			22.5°	0.018	0.033	0.051	0.074	0.100	0.131	0.204	0.294	0.401
			45°	0.028	0.049	0.077	0.111	0.152	0.198	0.309	0.445	0.606
			cfm	546	728	910	1092	1274	1456	1820	2184	2548
18x18	2.25	2.07	0°	0.016	0.029	0.046	0.066	0.090	0.117	0.183	0.263	0.358
			22.5°	0.018	0.033	0.051	0.074	0.100	0.131	0.204	0.294	0.401
			45°	0.028	0.049	0.077	0.111	0.152	0.198	0.309	0.445	0.606
			cfm	621	828	1035	1242	1449	1656	2070	2484	2898
42x8 24x14	2.33	2.14	0°	0.016	0.029	0.046	0.066	0.090	0.117	0.183	0.263	0.358
			22.5°	0.018	0.033	0.051	0.074	0.100	0.131	0.204	0.294	0.401
			45°	0.028	0.049	0.077	0.111	0.152	0.198	0.309	0.445	0.606
			cfm	642	856	1070	1284	1498	1712	2140	2568	2996
36x10 30x12	2.50	2.29	0°	0.016	0.029	0.046	0.066	0.090	0.117	0.183	0.263	0.358
			22.5°	0.018	0.033	0.051	0.074	0.100	0.131	0.204	0.294	0.401
			45°	0.028	0.049	0.077	0.111	0.152	0.198	0.309	0.445	0.606
			cfm	687	916	1145	1374	1603	1832	2290	2748	3206
48x8 24x16	2.67	2.46	0°	0.016	0.029	0.046	0.066	0.090	0.117	0.183	0.263	0.358
			22.5°	0.018	0.033	0.051	0.074	0.100	0.131	0.204	0.294	0.401
			45°	0.028	0.049	0.077	0.111	0.152	0.198	0.309	0.445	0.606
			cfm	738	984	1230	1476	1722	1968	2460	2952	3444
20x20	2.78	2.57	0°	0.016	0.029	0.046	0.066	0.090	0.117	0.183	0.263	0.358
			22.5°	0.018	0.033	0.051	0.074	0.100	0.131	0.204	0.294	0.401
			45°	0.028	0.049	0.077	0.111	0.152	0.198	0.309	0.445	0.606
			cfm	771	1028	1285	1542	1799	2056	2570	3084	3598
36x12 24x18	3.00	2.75	0°	0.016	0.029	0.046	0.066	0.090	0.117	0.183	0.263	0.358
			22.5°	0.018	0.033	0.051	0.074	0.100	0.131	0.204	0.294	0.401
			45°	0.028	0.049	0.077	0.111	0.152	0.198	0.309	0.445	0.606
			cfm	825	1100	1375	1650	1925	2200	2750	3300	3850

Performance notes appear at end of table

PERFORMANCE DATA

300 / 350 grilles

MODELS: 300R, 300F, 300R-SS, 300R-HD, 301R, 301F, 301R-SS AND 301R-HD
PERFORMANCE BASED ON NOMINAL SIZES SHOWN IN BOLD

Nom. Duct Size (in.)	Nom. Duct Area (ft ²)	Core Area (ft ²)	Core Vel. Vel. Press.	NC-20			NC-30			NC-40			NC-50		
				300	400	500	600	700	800	1000	1200	1400			
				0°	22.5°	45°	0°	22.5°	45°	0°	22.5°	45°	0°	22.5°	45°
48x10 30x16 24x20	3.33	3.11	cfm	933	1244	1555	1866	2177	2488	3110	3732	4354			
			NC	-	15	22	27	32	36	42	48	52			
			Throw (ft)	19-30-56	27-40-65	33-50-72	40-56-79	47-61-86	53-65-92	59-72-103	65-79-112	70-86-121			
			45°	15-23-44	21-31-50	26-39-56	31-44-62	36-47-66	41-50-71	46-56-79	50-62-87	54-66-94			
22x22	3.36	3.14	cfm	942	1256	1570	1884	2198	2512	3140	3768	4396			
			NC	-	15	22	27	32	36	42	48	53			
			Throw (ft)	19-30-56	27-40-65	34-50-73	40-56-80	47-61-86	53-65-92	59-73-103	65-80-113	70-86-122			
			45°	15-23-44	21-31-50	26-39-56	31-44-62	37-47-67	41-50-71	46-56-80	50-62-87	55-67-94			
42x12 36x14	3.50	3.22	cfm	966	1288	1610	1932	2254	2576	3220	3864	4508			
			NC	-	15	22	27	32	36	43	48	53			
			Throw (ft)	19-31-57	27-41-66	34-51-74	41-57-81	48-62-87	54-66-93	60-74-104	66-81-114	71-87-123			
			45°	15-24-44	21-32-51	26-40-57	32-44-63	37-48-68	42-51-72	47-57-81	51-63-89	55-68-96			
24x22	3.67	3.43	cfm	1029	1372	1715	2058	2401	2744	3430	4116	4802			
			NC	-	15	22	28	32	36	43	48	53			
			Throw (ft)	20-32-59	28-42-68	35-53-76	42-59-83	49-64-90	56-68-96	62-76-108	68-83-118	74-90-127			
			45°	15-25-46	22-33-53	27-41-59	33-46-65	38-49-70	43-53-75	48-59-83	53-65-91	57-70-99			
30x18	3.75	3.5	cfm	1050	1400	1750	2100	2450	2800	3500	4200	4900			
			NC	-	16	22	28	32	36	43	48	53			
			Throw (ft)	20-32-60	28-43-69	36-53-77	43-60-84	50-64-91	56-69-97	63-77-109	69-84-119	74-91-129			
			45°	15-25-46	22-33-53	28-41-60	33-46-65	39-50-71	44-53-75	49-60-84	53-65-92	58-71-100			
48x12 36x16 24x24	4.00	3.75	cfm	1125	1500	1875	2250	2625	3000	3750	4500	5250			
			NC	-	16	22	28	33	37	43	49	53			
			Throw (ft)	21-33-62	29-44-71	37-55-80	44-62-87	51-67-94	58-71-101	65-80-113	71-87-123	77-94-133			
			45°	16-26-48	23-34-55	29-43-62	34-48-68	40-52-73	45-55-78	50-62-87	55-68-96	60-73-103			
36x18	4.50	4.22	cfm	1266	1688	2110	2532	2954	3376	4220	5064	5908			
			NC	-	16	23	28	33	37	44	49	54			
			Throw (ft)	22-35-65	31-47-76	39-59-84	47-65-93	55-71-100	62-76-107	69-84-119	76-93-131	82-100-141			
			45°	17-27-51	24-36-59	30-45-65	36-51-72	42-55-77	48-59-83	53-65-93	59-72-101	63-77-110			
36x20 30x24	5.00	4.71	cfm	1413	1884	2355	2826	3297	3768	4710	5652	6594			
			NC	-	17	23	29	33	37	44	50	54			
			Throw (ft)	23-37-69	33-49-80	41-62-89	49-69-98	58-75-106	65-80-113	73-89-126	80-98-138	86-106-149			
			45°	18-29-54	26-38-62	32-48-69	38-54-76	45-58-82	50-62-87	56-69-98	62-76-107	67-82-116			
42x18	5.25	4.94	cfm	1482	1976	2470	2964	3458	3952	4940	5928	6916			
			NC	-	17	24	29	34	38	44	50	54			
			Throw (ft)	24-38-71	34-51-82	42-63-91	51-71-100	59-76-108	67-82-116	75-91-129	82-100-142	88-108-153			
			45°	18-29-55	26-39-63	33-49-71	39-55-78	46-59-84	52-63-90	58-71-100	63-78-110	68-84-118			
28x28	5.44	5.16	cfm	1548	2064	2580	3096	3612	4128	5160	6192	7224			
			NC	-	17	24	29	34	38	45	50	55			
			Throw (ft)	24-39-72	35-52-84	43-65-93	52-72-102	60-78-110	68-84-118	76-93-132	84-102-145	90-110-156			
			45°	19-30-56	27-40-65	33-50-72	40-56-79	47-61-86	53-65-92	59-72-102	65-79-112	70-86-121			
42x20 30x28	5.83	5.51	cfm	1653	2204	2755	3306	3857	4408	5510	6612	7714			
			NC	-	17	24	30	34	38	45	50	55			
			Throw (ft)	25-40-75	36-54-86	45-67-96	54-75-106	62-81-114	70-86-122	79-96-136	86-106-149	93-114-161			
			45°	19-31-58	28-41-67	35-52-75	41-58-82	48-63-88	55-67-95	61-75-106	67-82-116	72-88-125			
48x18 36x24	6.00	5.66	cfm	1698	2264	2830	3396	3962	4528	5660	6792	7924			
			NC	-	18	24	30	34	38	45	50	55			
			Throw (ft)	25-41-76	36-54-87	45-68-98	54-76-107	63-82-116	71-87-124	80-98-138	87-107-152	94-116-164			
			45°	20-32-59	28-42-68	35-53-76	42-59-83	49-63-90	55-68-96	62-76-107	68-83-117	73-90-127			
30x30	6.25	5.94	cfm	1782	2376	2970	3564	4158	4752	5940	7128	8316			
			NC	-	18	24	30	34	38	45	51	55			
			Throw (ft)	26-42-78	37-56-90	46-69-100	56-78-110	65-84-119	73-90-127	82-100-142	90-110-155	97-119-168			
			45°	20-32-60	29-43-69	36-54-78	43-60-85	50-65-92	57-69-98	63-78-110	69-85-120	75-92-130			

Performance notes appear at end of table

PERFORMANCE DATA

300 / 350 grilles

MODELS: 300R, 300F, 300R-SS, 300R-HD, 301R, 301F, 301R-SS AND 301R-HD
PERFORMANCE BASED ON NOMINAL SIZES SHOWN IN BOLD

Nom. Duct Size (in.)	Nom. Duct Area (ft²)	Core Area (ft²)	Core Vel. Vel. Press. 0° Total 22.5° Press. 45°	NC-20			NC-30			NC-40			NC-50		
				300	400	500	600	700	800	1000	1200	1400			
				0.006	0.010	0.016	0.022	0.031	0.040	0.062	0.090	0.122			
42x38	11.08	10.67	cfm	3201	4268	5335	6402	7469	8536	10670	12804	14938			
			NC	12	20	27	32	37	41	48	53	58			
			Throw 0°	35-56-104	50-74-120	62-93-134	74-104-147	87-112-159	98-120-170	110-134-190	120-147-208	130-159-225			
			Throw 22.5°	27-43-81	38-58-93	48-72-104	58-81-114	67-87-123	76-93-132	85-104-147	93-114-161	101-123-174			
40x40	11.11	10.7	Throw 45°	16-25-47	22-34-54	28-42-60	34-47-66	39-51-71	44-54-76	49-60-85	54-66-94	58-71-101			
			cfm	3210	4280	5350	6420	7490	8560	10700	12840	14980			
			NC	12	20	27	32	37	41	48	53	58			
			Throw 0°	35-56-104	50-75-120	62-93-134	75-104-147	87-113-159	98-120-170	110-134-190	120-147-208	130-159-225			
48x36	12.00	11.57	Throw 22.5°	27-43-81	39-58-93	48-72-104	58-81-114	67-87-123	76-93-132	85-104-147	93-114-161	101-123-174			
			Throw 45°	16-25-47	22-34-54	28-42-61	34-47-66	39-51-72	44-54-77	49-61-86	54-66-94	58-72-101			
			cfm	3471	4628	5785	6942	8099	9256	11570	13884	16198			
			NC	12	21	27	33	37	41	48	53	58			
42x42	12.25	11.82	Throw 0°	37-59-109	52-78-126	65-98-141	78-109-155	91-118-167	103-126-179	115-141-200	126-155-219	137-167-236			
			Throw 22.5°	28-46-85	40-61-98	51-76-110	61-85-120	71-92-130	80-98-139	89-110-155	98-120-170	106-130-183			
			Throw 45°	16-26-49	24-35-57	29-44-64	35-49-70	41-53-75	46-57-80	52-64-90	57-70-99	61-75-106			
			cfm	3546	4728	5910	7092	8274	9456	11820	14184	16548			
44x44	13.44	12.99	NC	12	21	28	33	38	42	48	54	58			
			Throw 0°	38-62-115	55-82-133	68-103-148	82-115-162	96-124-175	108-133-187	121-148-210	133-162-230	143-175-248			
			Throw 22.5°	30-48-89	42-64-103	53-80-115	64-89-126	74-96-136	84-103-145	94-115-162	103-126-178	111-136-192			
			Throw 45°	17-28-52	25-37-60	31-46-67	37-52-73	43-56-79	49-60-84	54-67-94	60-73-103	64-79-112			
48x42	14.00	13.54	cfm	4062	5416	6770	8124	9478	10832	13540	16248	18956			
			NC	13	21	28	33	38	42	49	54	59			
			Throw 0°	39-63-117	56-84-135	70-105-151	84-117-166	98-127-179	110-135-191	124-151-214	135-166-234	146-179-253			
			Throw 22.5°	30-49-91	43-65-105	54-81-117	65-91-128	76-98-139	86-105-148	96-117-166	105-128-182	113-139-196			
46x46	14.69	14.22	Throw 45°	18-28-53	25-38-61	31-47-68	38-53-75	44-57-81	50-61-86	56-68-96	61-75-105	66-81-114			
			cfm	4266	5688	7110	8532	9954	11376	14220	17064	19908			
			NC	13	21	28	33	38	42	49	54	59			
			Throw 0°	40-64-120	57-86-139	72-107-155	86-120-170	100-130-183	113-139-196	127-155-219	139-170-240	150-183-259			
48x46	15.33	14.85	Throw 22.5°	31-50-93	44-67-107	56-83-120	67-93-132	78-101-142	88-107-152	98-120-170	107-132-186	116-142-201			
			Throw 45°	18-29-54	26-39-62	32-48-70	39-54-76	45-58-83	51-62-88	57-70-99	62-76-108	67-83-117			
			cfm	4455	5940	7425	8910	10395	11880	14850	17820	20790			
			NC	13	22	28	34	38	42	49	54	59			
48x48	16.00	15.50	Throw 0°	41-66-123	59-88-142	73-110-158	88-123-174	102-133-187	116-142-200	129-158-224	142-174-245	153-187-265			
			Throw 22.5°	32-51-95	45-68-110	57-85-123	68-95-134	79-103-145	90-110-155	100-123-174	110-134-190	119-145-205			
			Throw 45°	18-30-55	26-40-64	33-49-71	40-55-78	46-60-84	52-64-90	58-71-101	64-78-110	69-84-119			
			cfm	4650	6200	7750	9300	10850	12400	15500	18600	21700			
48x48	16.00	15.50	NC	13	22	28	34	38	42	49	55	59			
			Throw 0°	42-67-125	60-90-145	75-112-162	90-125-177	105-135-192	118-145-205	132-162-229	145-177-251	156-192-271			
			Throw 22.5°	33-52-97	46-70-112	58-87-125	70-97-137	81-105-148	92-112-159	102-125-177	112-137-194	121-148-210			
			Throw 45°	19-30-56	27-40-65	34-50-73	40-56-80	47-61-86	53-65-92	59-73-103	65-80-113	70-86-122			

- 0°, 22.5° & 45° represent blade deflection angles
- Performance data is based on duct sizes in bold, the performance varies slightly for duct sizes not shown in bold
- See the section, Engineering Guidelines, for drop information when selecting larger supply grilles for cooling purposes
- See the "Performance Notes" portion in this section for notes and correction factors

- See the section, Engineering Guidelines, for catalog throw information
- Each NC value represents the noise criteria curve that will not be exceeded by the sound pressure in any of the octave bands, 2 through 7, with a room absorption of 10 dB, re 10⁻¹² watts

PERFORMANCE NOTES

- Performance data includes damper
- Data obtained from tests conducted in accordance with ANSI/ASHRAE Standard 70-2006
- All pressures are in inches of water
- Core velocities are in feet per minute
- Throw values given are for isothermal terminal velocities of 150, 100 and 50 fpm
- Each NC value represents the noise criterion curve that will not be exceeded by the sound pressure in any of the octave bands, 2 through 7. Each NC value is based on a room absorption of 10 dB, re 10⁻¹² watts. Each NC value is further based on grille operating at a 0° deflection. Settings of 22½° or 45°, increase the stated sound levels by 1 or 7 NC, respectively.
- Bold dividing lines on H12-H16 denote ranges of NC values
- The stated deflection settings refer to the horizontal setting of the blade's deflection angle. For a 20° upward deflection, use the throw rating for the 0° setting and the total pressure for the 22½° horizontal setting.
- Dash (—) in space indicates NC value less than 10
- For additional information concerning drop and throw, see the Engineering Guidelines section of this catalog

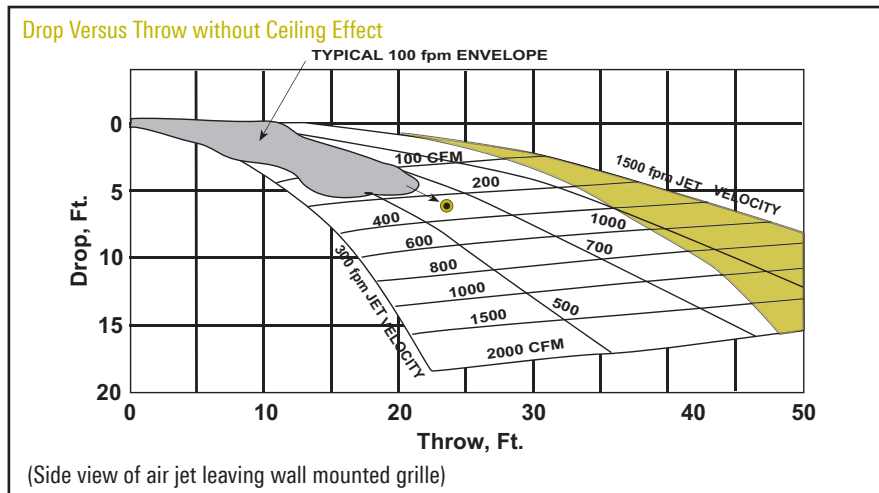
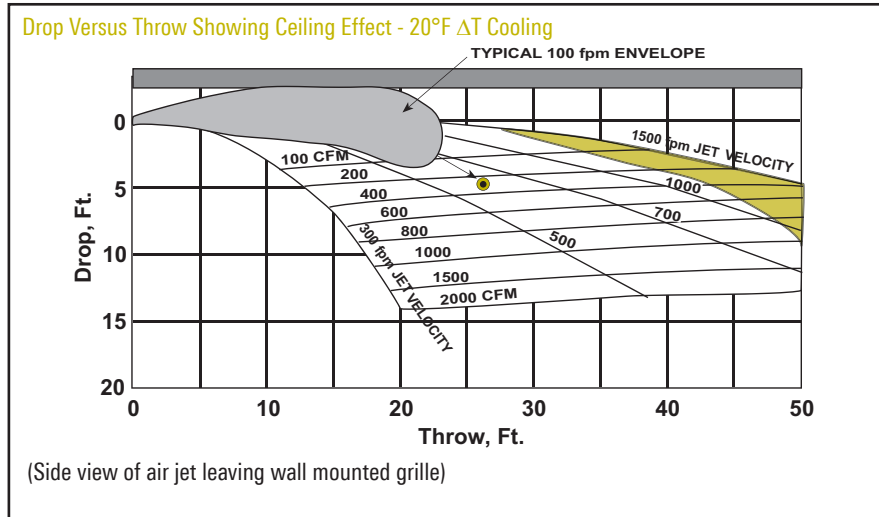

VARIABLE AIR VOLUME APPLICATIONS

All Titus supply grilles can be applied to variable air volume systems with excellent results. For detailed selection methods, consult your Titus representative or the Engineering Guidelines section of this catalog.

Correction Factors for 300/301 Supply Grilles

Model	Damper	A _k / A _c	Throw	Total Pressure	NC
300R, 300F	With	0.77	1.00	1.00	0
301R, 301F	Without	0.82	0.98	0.88	-2

Note: Throw and total pressure corrections are multipliers. The NC correction is an addition. A_k is the flow factor. A_c is the core area from the main table.

HORIZONTAL DEFLECTION (SPREAD)

SUPPLY GRILLES

The figures depicting deflection, throw and drop are based on actual tests conducted by Titus. They show the relationship of spread to throw for a typical high side-wall supply outlet selection.

Notice the outer shaded area represents the 50 fpm isovel, the white area, the 100 fpm isovel, and the inner area, the 150 fpm isovel.

The spread angle also affects the airstream drop amount. Always consider for any given temperature, volume and core velocity; the wider spread results in a smaller drop. See section, Engineering Guidelines, for more drop, throw and spread relationship information.

Titus grilles can be selected with a single set of blades for adjusting either horizontal or vertical deflection, or with two sets of blades for adjusting both horizontal and vertical deflections.

0° Horizontal Deflection

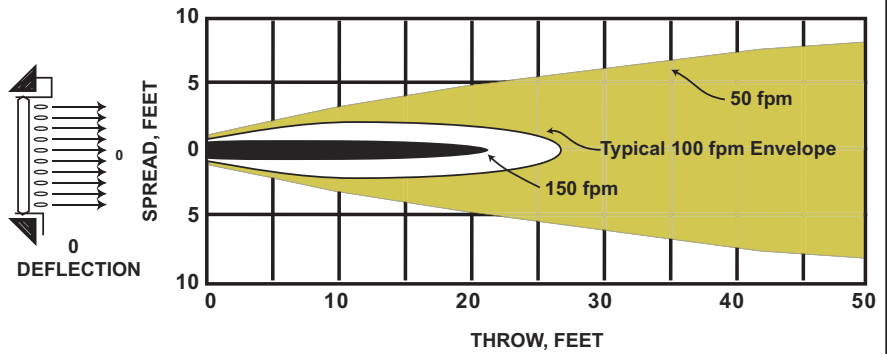

Spread versus throw at 0° horizontal deflection angle (Plan view of air jet leaving wall mounted grille).

22½° Horizontal Deflection

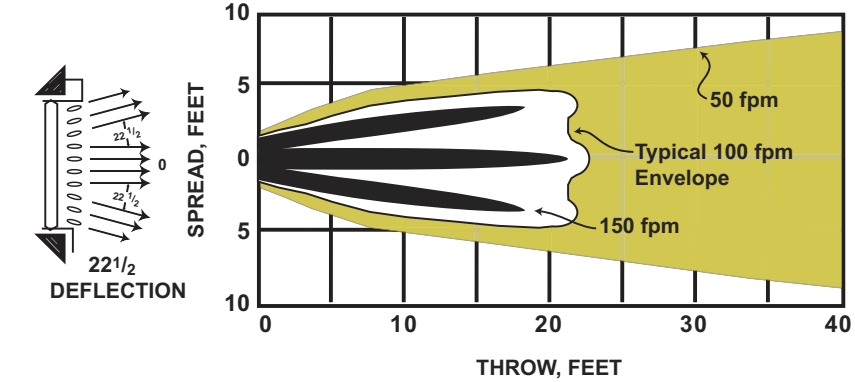

Spread versus throw at 22½° horizontal deflection angle (Plan view of air jet leaving wall mounted grille).

45° Horizontal Deflection

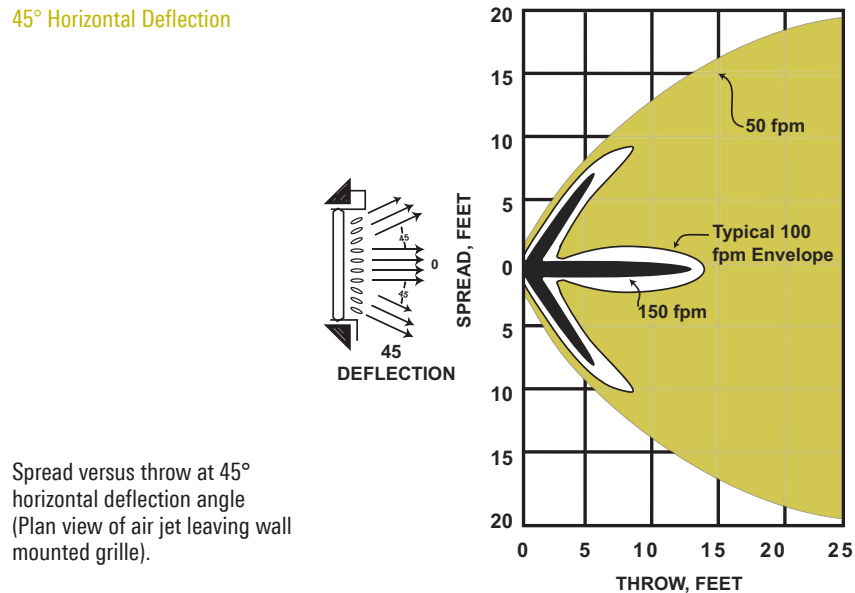

Spread versus throw at 45° horizontal deflection angle (Plan view of air jet leaving wall mounted grille).

R-301F / R-300F

R-301F

- Grilles can be surface mounted or duct mounted. Mounting bracket is installed and grille is inserted and rotated for quick mounting.
- 3/4" blade spacing
- Single deflection
- Adjustable louvers
- All aluminum construction with radius end caps to match duct diameters from 6" thru 36" in even increments

R-300FS

- Grilles can be surface mounted or duct mounted. Mounting bracket is installed and grille is inserted and rotated for quick mounting.
- 3/4" blade spacing
- Double deflection
- Adjustable louvers
- All aluminum construction with radius end caps to match duct diameters from 6" thru 36" in even increments



R-301F

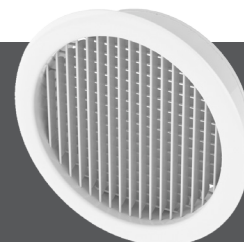

R-300F



metric sizes

AVAILABLE MODELS:

Single Deflection Model
R-301F

Double Deflection Model
R-300F

FINISHES

Standard Finish - #26 White
Optional Finish - #04 Mill

OVERVIEW

3/4" Blade Spacing / Aluminum

Titus' R-300F/R-301F series is a round all-aluminum supply grille offering. These distinctive grilles are the perfect complement to our standard 300 series that will meet any application requirements.



See website for Specifications

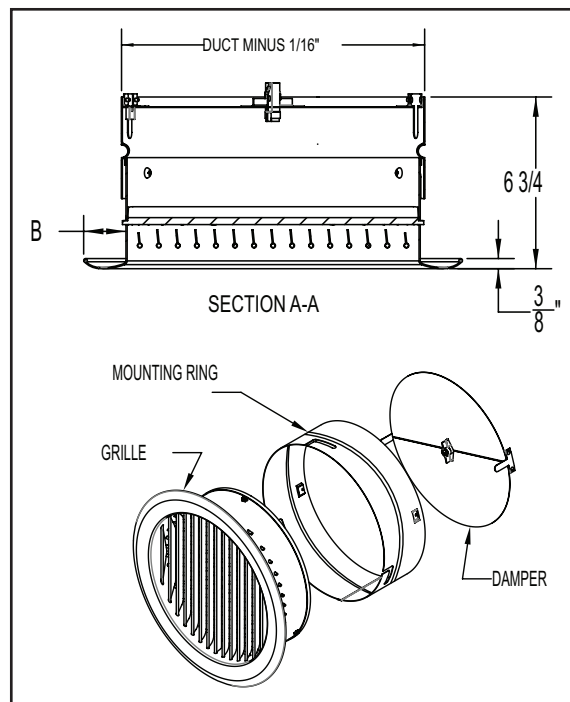

Damper option

R-301F / R-300F DIMENSIONS

Single Deflection Model R-301F

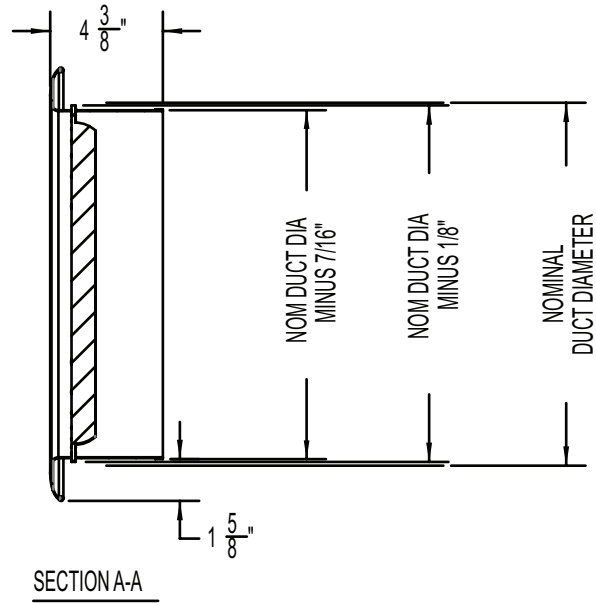
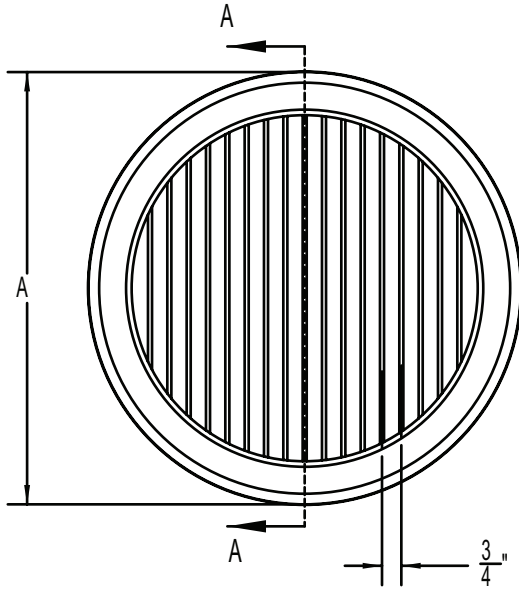

Double Deflection Model R-300F

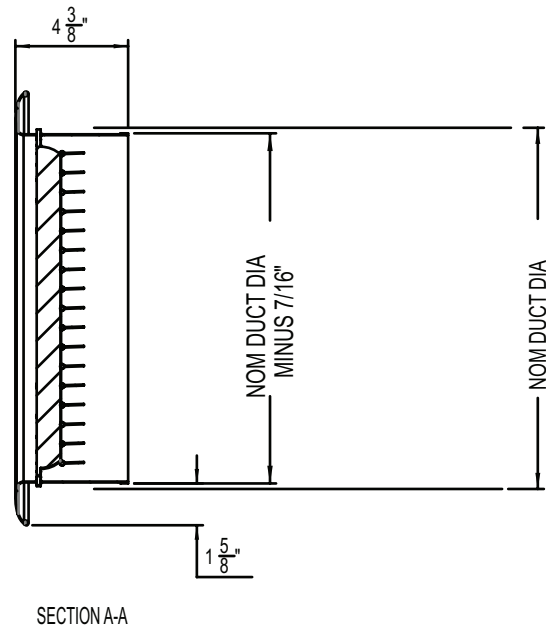
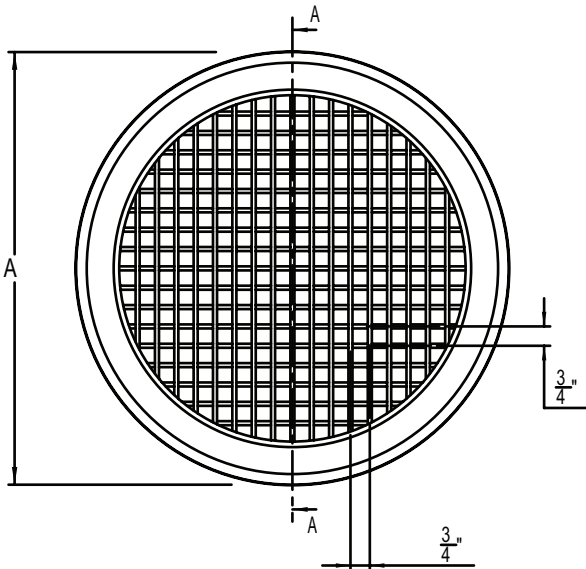

MODELS: R-301F / R-300F

Nominal Duct Size	Nom. Duct Area (ft ²)	Duct Velocity, fpm	300	400	500	600	700	800	900	1000	1100	1200	1300	
		Velocity Pressure, IN WG	0.006	0.010	0.016	0.022	0.031	0.040	0.050	0.062	0.075	0.090	0.105	
6 Ak=.125	0.196	Air Flow, cfm	38	50	63	75	88	100	113	125	138	150	163	
		Total Pressure, IN WG	0.004	0.007	0.011	0.016	0.021	0.028	0.035	0.044	0.053	0.063	0.074	
		NC (Noise Criteria)	-	-	-	-	-	-	-	-	-	-	-	-
		Throw, FT	3-4-8	4-6-12	5-7-14	6-9-17	6-10-19	7-11-21	8-13-25	20-28-40	10-15-30	11-17-34	13-19-38	
8 Ak=.229	0.349	Air Flow, cfm	69	92	115	138	161	184	206	229	252	275	298	
		Total Pressure, IN WG	0.004	0.007	0.011	0.015	0.021	0.027	0.035	0.043	0.052	0.062	0.072	
		NC (Noise Criteria)	-	-	-	-	-	-	-	-	-	-	-	-
		Throw, FT	3-5-10	4-7-13	5-8-16	6-10-19	7-11-22	8-13-25	10-15-29	10-16-31	12-18-35	13-19-38	14-21-41	
10 Ak=.367	0.545	Air Flow, cfm	110	147	183	220	257	293	330	367	403	440	477	
		Total Pressure, IN WG	0.004	0.007	0.010	0.015	0.021	0.027	0.034	0.042	0.051	0.060	0.071	
		NC (Noise Criteria)	-	-	-	-	-	-	-	-	-	-	-	-
		Throw, FT	3-5-10	5-7-14	6-9-17	7-11-21	8-12-24	10-15-29	11-16-32	12-18-36	13-20-39	14-22-43	15-23-46	
12 Ak=.538	0.785	Air Flow, cfm	161	215	269	323	376	430	484	538	592	645	699	
		Total Pressure, IN WG	0.004	0.007	0.010	0.015	0.020	0.026	0.033	0.041	0.049	0.059	0.069	
		NC (Noise Criteria)	-	-	-	-	-	-	-	-	-	-	-	21
		Throw, FT	4-6-12	5-8-16	7-10-20	8-12-24	9-14-28	10-16-31	12-18-36	13-20-39	15-22-44	16-24-47	17-26-51	
14 Ak=.743	1.069	Air Flow, cfm	223	297	372	446	520	595	669	743	818	892	966	
		Total Pressure, IN WG	0.004	0.006	0.010	0.014	0.019	0.025	0.032	0.039	0.047	0.056	0.066	
		NC (Noise Criteria)	-	-	-	-	-	-	-	-	-	-	22	25
		Throw, FT	4-6-12	6-9-17	7-11-21	8-13-25	10-15-29	11-17-33	13-19-38	14-21-42	15-23-45	17-25-50	18-27-54	
16 Ak=.984	1.396	Air Flow, cfm	295	394	492	590	689	787	886	984	1082	1181	1279	
		Total Pressure, IN WG	0.003	0.006	0.009	0.014	0.018	0.024	0.030	0.038	0.045	0.054	0.063	
		NC (Noise Criteria)	-	-	-	-	-	-	-	-	22	25	28	
		Throw, FT	4-7-13	6-9-17	7-11-22	9-13-26	10-15-30	12-18-35	13-20-39	15-22-44	16-24-48	17-26-52	19-29-57	
18 Ak=1.260	1.767	Air Flow, cfm	378	504	630	756	882	1008	1134	1260	1386	1512	1638	
		Total Pressure, IN WG	0.003	0.006	0.009	0.013	0.018	0.023	0.029	0.036	0.043	0.051	0.060	
		NC (Noise Criteria)	-	-	-	-	-	-	-	22	26	29	32	
		Throw, FT	5-7-14	6-9-18	8-12-23	9-14-28	11-16-32	12-19-37	14-21-41	15-23-45	17-26-51	18-28-55	20-30-59	
20 Ak=1.572	2.182	Air Flow, cfm	472	629	786	943	1101	1258	1415	1572	1730	1887	2044	
		Total Pressure, IN WG	0.003	0.005	0.008	0.012	0.016	0.021	0.027	0.033	0.040	0.048	0.057	
		NC (Noise Criteria)	-	-	-	-	-	-	21	25	28	31	34	
		Throw, FT	5-8-15	6-10-19	8-12-24	10-15-30	11-17-34	13-19-38	14-22-43	16-24-47	18-27-53	19-29-58	21-31-62	

- Throw values given are for terminal velocities of 150, 100 and 50 fpm and for isothermal conditions. Data is for double deflection model set at bi-directional spread pattern of 22°. See the section, Engineering Guidelines for additional throw information.
- The throw values listed are without ceiling effect. For throw values with ceiling effect apply a correction factor of 1.4.
- All pressures given are in inches of water
- Velocity pressure is based on inlet duct area and velocity
- To obtain static pressure, subtract the velocity pressure from the total pressure
- Noise criteria (NC) is based on an absorption in the room of 10 db 10⁻¹² watts evaluated in octaves in range from 125 to 4000 Hz. Dash (-) in space denotes an NC value of less than 20.
- Data was obtained by tests conducted in accordance with standard ANSI/ASHRAE 70-2006 under isothermal conditions. Actual performance with flexible duct may vary. See the section, Engineering Guidelines for additional information.

300 / 350 Return Grilles

300 / 350 grilles

350 (RL-RS / ZRL-ZRS)

350RL

- 3/4" blade spacing
- 35° fixed deflection
- Reinforced corners
- Blades parallel to the long dimension

350RS

- Same as 350RL with blades parallel to the short dimension

350ZRL

- 3/4" blade spacing
- 0° fixed deflection
- Reinforced corners
- Blades parallel to the long dimension

350ZRS

- Same as 350ZRL with blades parallel to the short dimension

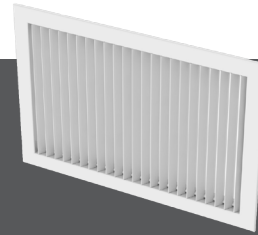

350 (RL / RS)



350 (ZRL / ZRS)



metric sizes

AVAILABLE MODELS:

35° Deflection Models

350RL
350RS

0° Deflection Models

350ZRL
350ZRS

FINISH

Standard Finish - #26 White

OVERVIEW

3/4" Blade Spacing / Steel

Titus' 300 / 350 Series return grilles define the standard for the industry. With high quality and competitive pricing these grilles form the backbone of a standard offering that will meet any application requirements.

For Performance Data, refer to page H37 for 350R, and page H39 for 350ZR.

PRODUCTS INCLUDE

- Material: Roll-formed Steel Border and Blades
- Welded Border
- Available Border Types:
 - #1 - Surface Mount
 - #2 - Snap-In
 - #3 - Lay-In
 - #4 - Spline



See website for Specifications

- Countersunk Screw Holes
- #8 x 1/4" Long Phillips Flat Head Sheet Metal Screws, Painted White
- Optional Steel Opposed-Blade Damper

DIMENSIONS

350 (RL-RS / ZRL-ZRS) DIMENSIONS

35° Deflection Models 350RL / RS - Border Type 1

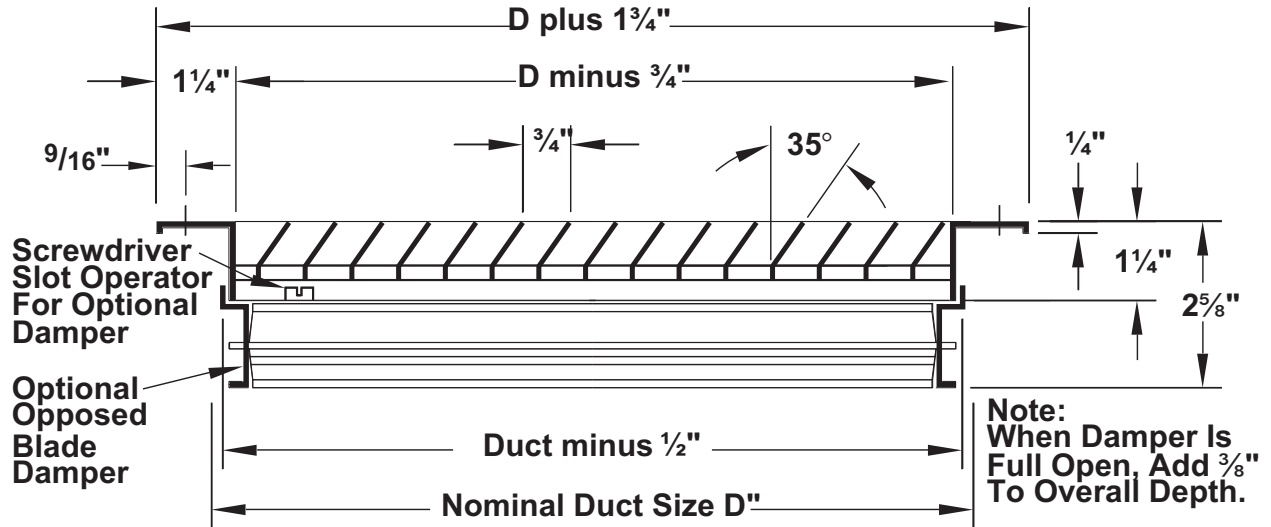

Available sizes (D" x D") are 6 x 4 inches through 48 x 48 inches in 1" increments
 Odd and fractional sizes are available at additional cost

0° Deflection Models 350ZRL / ZRS - Border Type 1

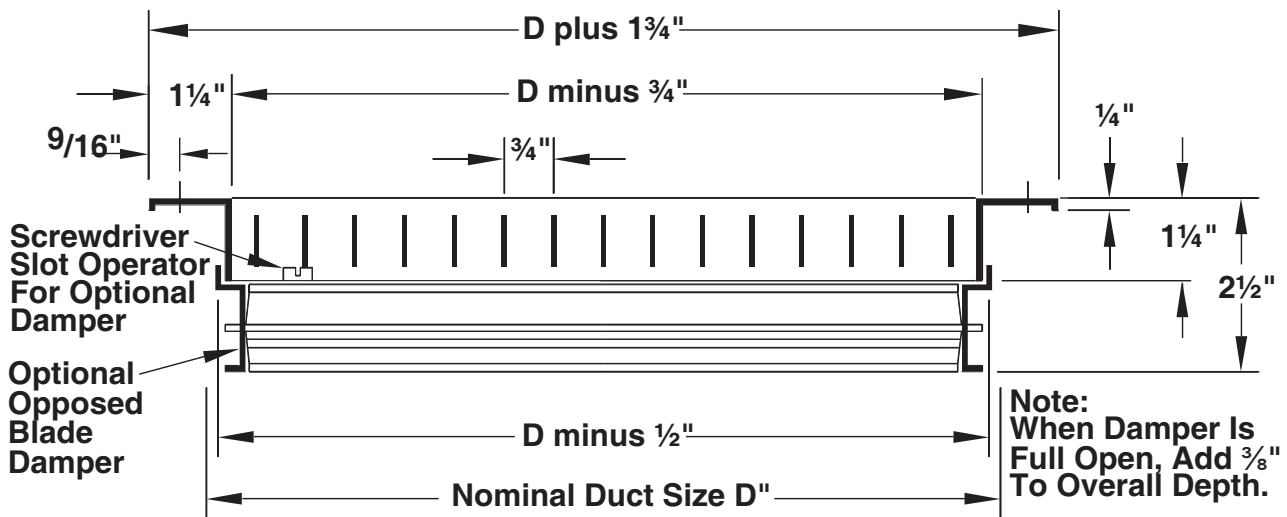

Available sizes (D" x D") are 6 x 4 inches through 48 x 48 inches in 1" increments
 Odd and fractional sizes are available at additional cost

350 (FL-FS / ZFL-ZFS)

350FL

- Great for areas with high humidity or subject to moisture
- ¾" blade spacing
- 35° fixed deflection
- Reinforced corners
- Blades parallel to the long dimension
- MRI compatible

350FS

- Same as 350FL with blades parallel to the short dimension

350ZFL

- Great for areas with high humidity or subject to moisture
- ¾" blade spacing
- 0° fixed deflection
- Reinforced corners
- Blades parallel to the long dimension

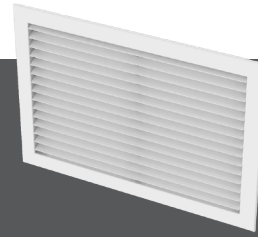

350 (FL / FS)

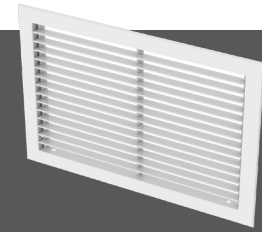

350 (ZFL / ZFS)

- MRI compatible

350ZFS

- Same as 350ZFL with front blades parallel to the short dimension



metric sizes



humid areas



MRI compatible

AVAILABLE MODELS:

35° Deflection Models

350FL
350FS

0° Deflection Models

350ZFL
350ZFS

FINISH

Standard Finish - #26 White

OVERVIEW

¾" Blade Spacing / Aluminum

Titus' 300 / 350 Series return grilles define the standard for the industry. With high quality and competitive pricing these grilles form the backbone of a standard offering that will meet any application requirements.

For Performance Data, refer to page H37 for 350R, and page H39 for 350ZR.

PRODUCTS INCLUDE

- Material: Roll-formed Aluminum Border and Blades on sizes up to 24 x 24 inches. Extruded Aluminum Border for Larger Sizes.
- Welded Border.
- Available Border Types:
 - #1 - Surface Mount
 - #2 - Snap-In
 - #3 - Lay-In
 - #4 - Spline
- Countersunk Screw Holes



See website for Specifications

- #8 x 1¼" Long Phillips Flat Head Sheet Metal Screws, Painted White
- Optional Steel or Aluminum Opposed-Blade Damper

DIMENSIONS

350 (FL-FS / ZFL-ZFS) DIMENSIONS

35° Deflection Models: 350FL / 350FS - Border Type 1

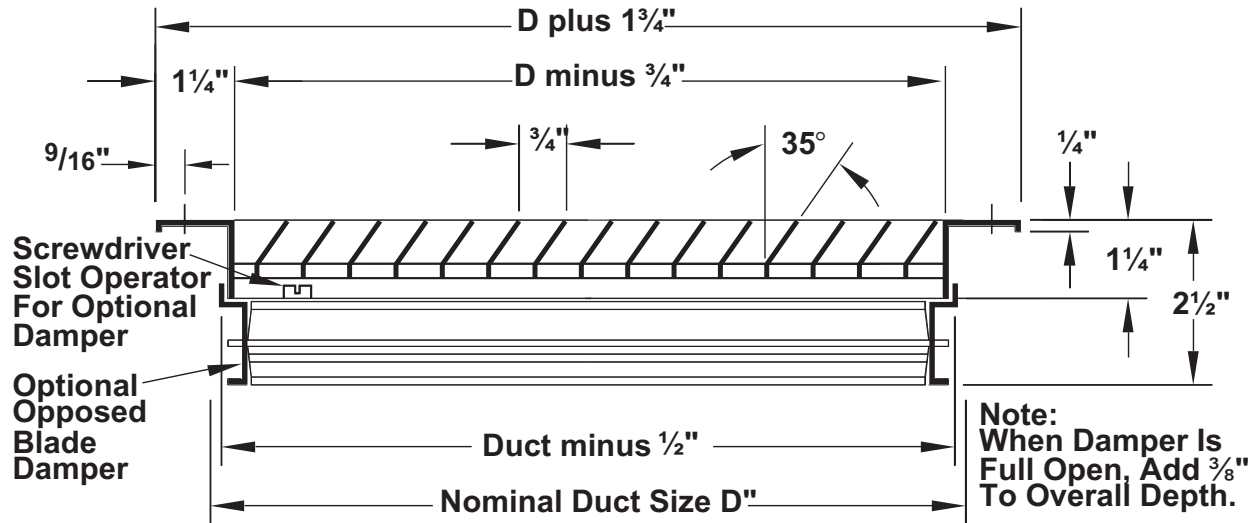

Available sizes (D" x D") are 6 x 4 inches through 48 x 48 inches in 1" increments
Odd and fractional sizes are available at additional cost

0° Deflection Models: 350ZFL / 350ZFS - Border Type 1

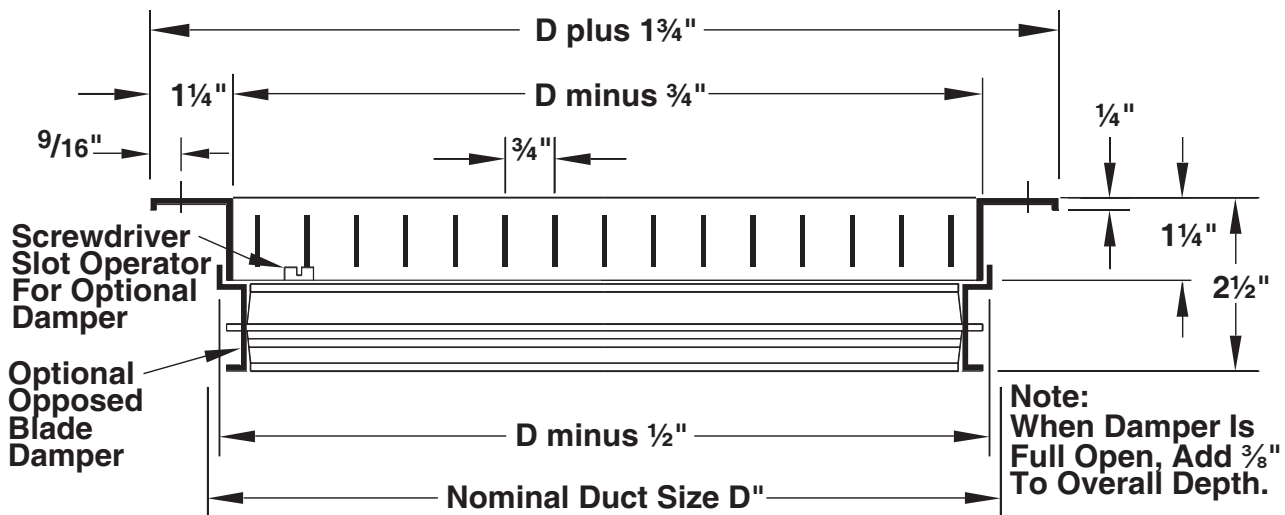

Available sizes (D" x D") are 6 x 4 inches through 48 x 48 inches in 1" increments
Odd and fractional sizes are available at additional cost

350 (RL-SS / RS-SS)

350RL-SS

- Great for use in corrosive environments
- ¾" blade spacing
- 45° fixed deflection
- Blades parallel to the long dimension
- Available in 316 Stainless Steel

350RS-SS

- Same as 350RL-SS with blades parallel to short dimension
- Tightly mitered corners
- Uniform polish finish
- Hollow airfoil blades anchored with nylon pivots for tight fit and no rattling
- Exclusive tooling and roll-forming equipment means metal is not contaminated with fragments of steel or aluminum

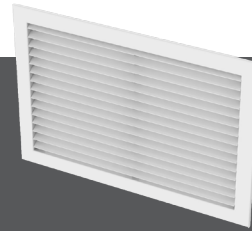

350 (RL-SS)

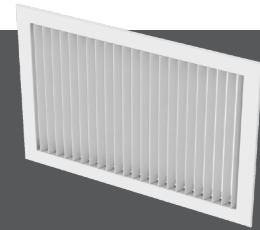

350 (RS-SS)



metric sizes



prevents corrosion

AVAILABLE MODELS:

45° Deflection Models

350RL-SS

350RS-SS

FINISH

Standard Finish - #04 Mill

OVERVIEW

¾" Blade Spacing / Stainless Steel

Titus' 300 / 350 Series return grilles define the standard for the industry. With high quality and competitive pricing these grilles form the backbone of a standard offering that will meet any application requirements.

For Performance Data, refer to page H33.

PRODUCTS INCLUDE

- Material: 304 Stainless Steel Border and Blades.
- Available Border Types:
 - #1 - Surface Mount
- Countersunk Screw Holes
- #8 x 1¼" Long 304 Stainless Steel Phillips Flat Head Sheet Metal Screws
- Optional 304 Stainless Steel Opposed-Blade Damper



See website for Specifications

DIMENSIONS

350 (RL-SS / RS-SS) DIMENSIONS

45° Deflection Models: 350RL-SS / 350RS-SS - Border Type 1

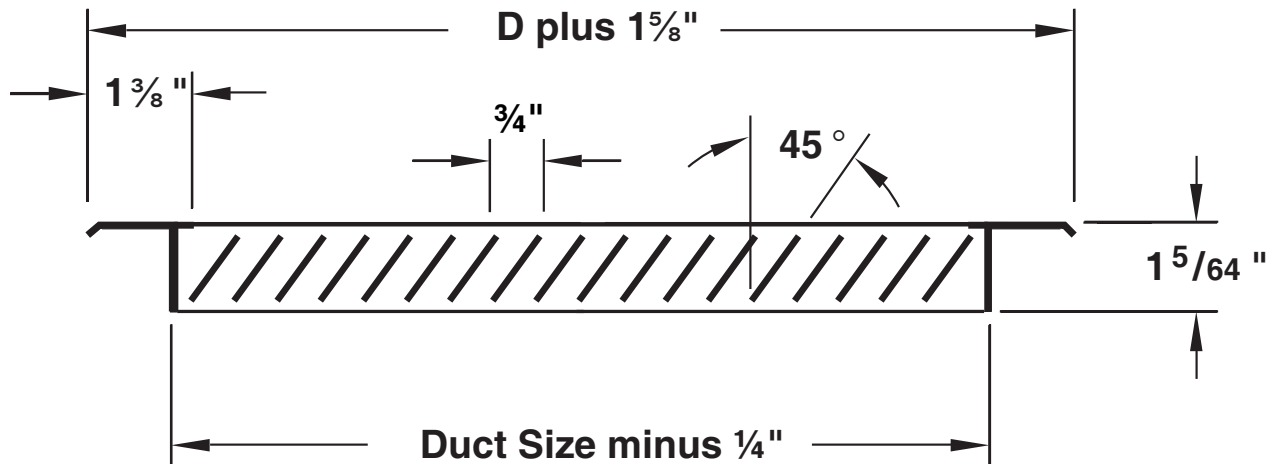

Available sizes (D" x D") are 6 x 4 inches through 48 x 48 inches in 1" increments
Odd and fractional sizes are available at additional cost

STAINLESS STEEL MATERIAL PROPERTIES AND CHARACTERISTICS

TYPE 304 STAINLESS STEEL

Type 304, with its chromium-nickel content and low carbon, is the most versatile and widely used type of stainless steel. It possesses characteristics that provide resistance to oxidation and corrosion. Type 304 stainless steel provides good resistance to moderately acidic or caustic solutions.

TYPE 316 STAINLESS STEEL

Type 316 is a chromium-nickel stainless and heat resisting steel with superior corrosion resistance, as compared to other chromium-nickel steels, when exposed to many types of chemical corrosives such as sea water, brine solutions and the like. The addition of two percent molybdenum makes type 316 more resistant to corrosion and oxidation. Type 316 is considerably more resistant to solutions of sulfuric acid, chlorides, bromides and fatty acids at high temperatures. In the manufacture of pharmaceuticals, stainless steels containing molybdenum are required in order to avoid excessive metallic contamination.

STAINLESS STEEL APPLICATIONS

Stainless steel is the number one preferred material for those situations where corrosion, rusting or deterioration is a problem. However, that is just where the uses begin.

When a high-tech effect is desired in a restaurant, hotel or corporate lobby, nothing beats the clean lines and aesthetic beauty of stainless steel.

There are literally hundreds of additional applications, some include:

- Pharmaceutical Plants
- Food Processing Plants
- Showers and Locker Rooms
- Commercial Kitchens
- Wastewater Treatment Plants
- Bio-Medical Manufacturing
- Coastal Areas
- Industrial Applications
- Clean Rooms
- Laboratories
- Hospitals
- Dairy Facilities
- Beverage Plants
- Chemical Plants and Schools

355 (RL-RS / ZRL-ZRS)

355RL

- ½" blade spacing
- 35° fixed deflection
- Reinforced corners
- Blades parallel to the long dimension

355RS

- Same as 355RL with blades parallel to the short dimension

355ZRL

- ½" blade spacing
- 0° fixed deflection
- Reinforced corners
- Blades parallel to the long dimension

355ZRS

- Same as 355ZRL with front blades parallel to the short dimension

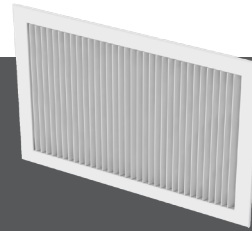

355 (RL / RS)

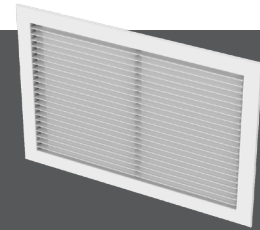

355 (ZRL / ZRS)



metric sizes

AVAILABLE MODELS:

35° Deflection Models

355RL
355RS

0° Deflection Models

355ZRL
355ZRS

FINISH

Standard Finish - #26 White

OVERVIEW

½" Blade Spacing / Steel

Titus' 300 / 350 Series return grilles define the standard for the industry. With high quality and competitive pricing these grilles form the backbone of a standard offering that will meet any application requirements.

For Performance Data, refer to page H37 for 355R, and page H39 for 355ZR.

PRODUCTS INCLUDE

- Material: Roll-formed Steel Border and Blades
- Welded Border
- Available Border Types:
 - #1 - Surface Mount
 - #2 - Snap-In
 - #3 - Lay-In
 - #4 - Spline



See website for Specifications

- Countersunk Screw Holes
- #8 x 1¼" Long Phillips Flat Head Sheet Metal Screws, Painted White
- Optional Steel Opposed-Blade Damper

DIMENSIONS

355 (RL-RS / ZRL-ZRS) DIMENSIONS

35° Deflection Models: 355RL / 355RS - Border Type 1

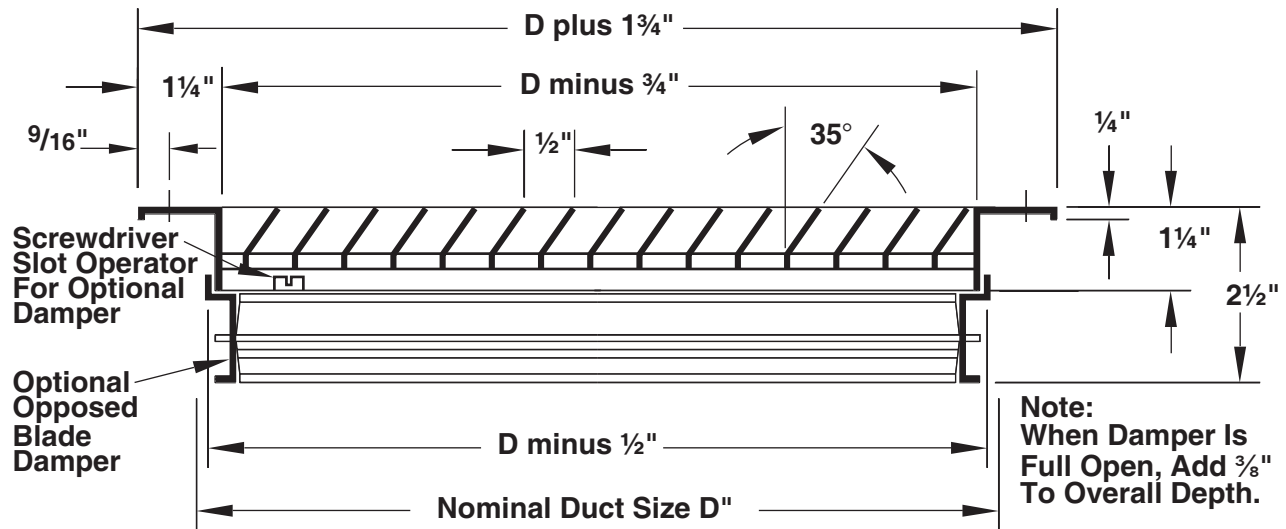

Available sizes (D" x D") are 6 x 4 inches through 48 x 48 inches in 1" increments
Odd and fractional sizes are available at additional cost

0° Deflection Models: 355ZRL / 355ZRS - Border Type 1

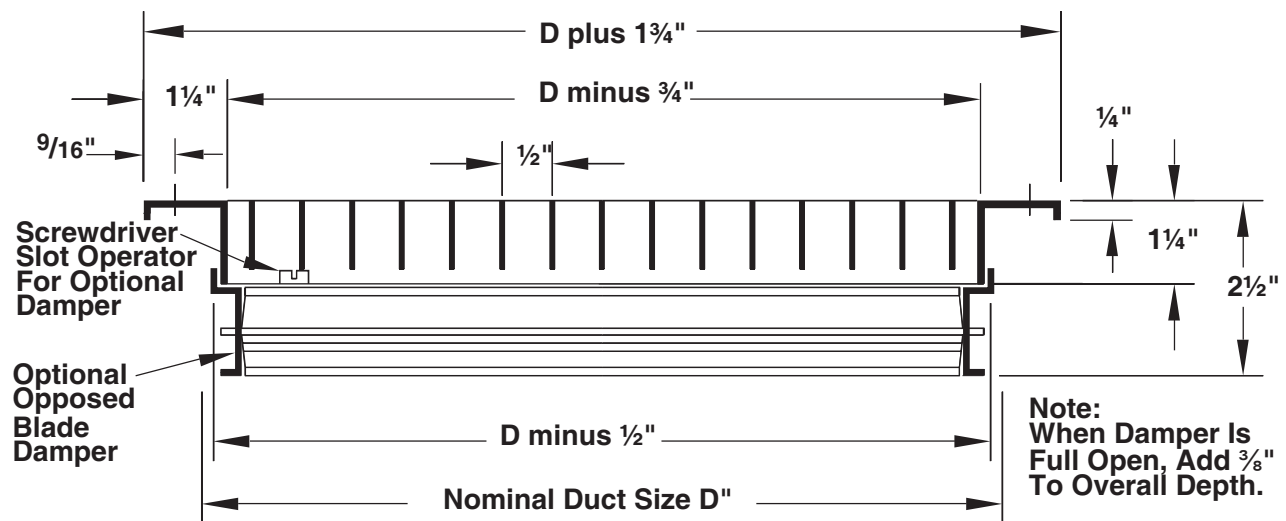

Available sizes (D" x D") are 6 x 4 inches through 48 x 48 inches in 1" increments
Odd and fractional sizes are available at additional cost

355 (FL-FS / ZFL-ZFS)

355FL

- Great for areas with high humidity or subject to moisture
- ¾" blade spacing
- 35° fixed deflection
- Reinforced corners
- Blades parallel to the long dimension
- MRI compatible

355FS

- Same as 355FL with blades parallel to the short dimension

355ZFL

- Great for areas with high humidity or subject to moisture
- ¾" blade spacing
- 0° fixed deflection
- Reinforced corners
- Blades parallel to the long dimension

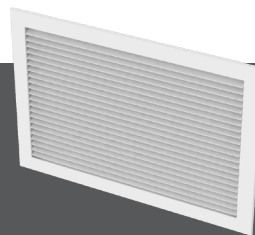

355 (FL / FS)

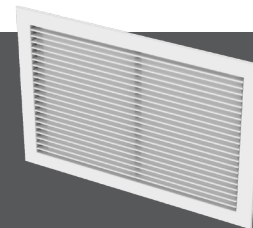

355 (ZFL / ZFS)

- MRI compatible

355ZFS

- Same as 355ZFL with front blades parallel to the short dimension



metric sizes



humid areas



MRI compatible

AVAILABLE MODELS:

35° Deflection Models

355FL
355FS

0° Deflection Models

355ZFL
355ZFS

FINISH

Standard Finish - #26 White

OVERVIEW

½" Blade Spacing / Aluminum

Titus' 300 / 350 Series return grilles define the standard for the industry. With high quality and competitive pricing these grilles form the backbone of a standard offering that will meet any application requirements.

For Performance Data, refer to page H37 for 355R, and page H39 for 355ZR.

PRODUCTS INCLUDE

- Material: Roll-formed Aluminum Border and Blades on sizes up to 24 x 24 inches. Extruded Aluminum Border for Larger Sizes.
- Welded Border
- Available Border Types:
 - #1 - Surface Mount
 - #2 - Snap-In
 - #3 - Lay-In
 - #4 - Spline
- Countersunk Screw Holes



See website for Specifications

- #8 x 1¼" Long Phillips Flat Head Sheet Metal Screws, Painted White
- Optional Steel or Aluminum Opposed-Blade Damper

DIMENSIONS

355 (FL-FS / ZFL-ZFS) DIMENSIONS

35° Deflection Models: 355FL / 355FS - Border Type 1

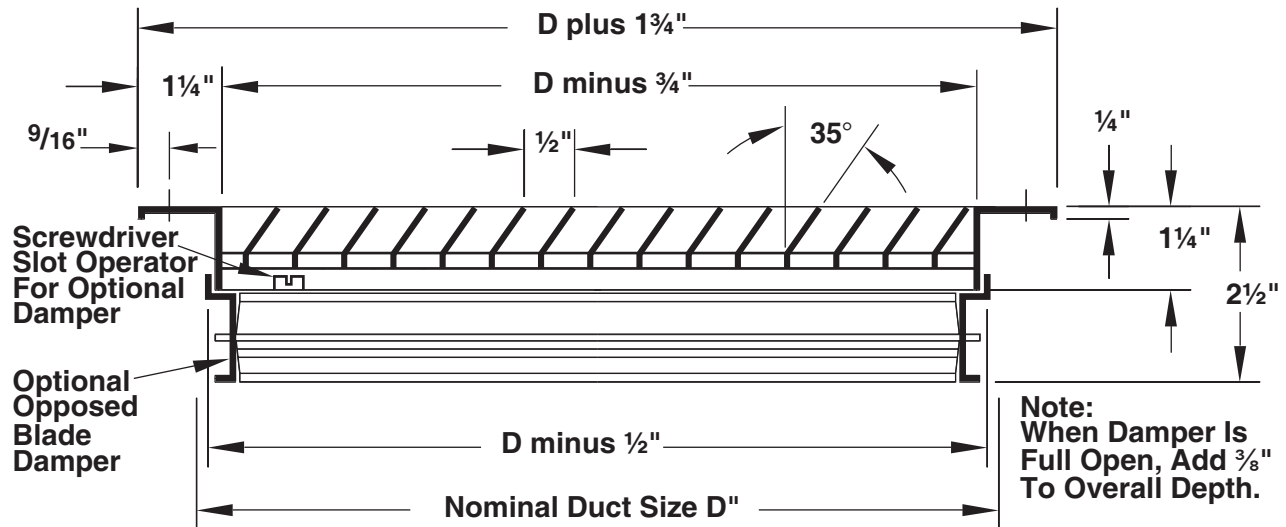

Available sizes (D" x D") are 6 x 4 inches through 48 x 48 inches in 1" increments
Odd and fractional sizes are available at additional cost

0° Deflection Models: 355ZFL / 355ZFS - Border Type 1

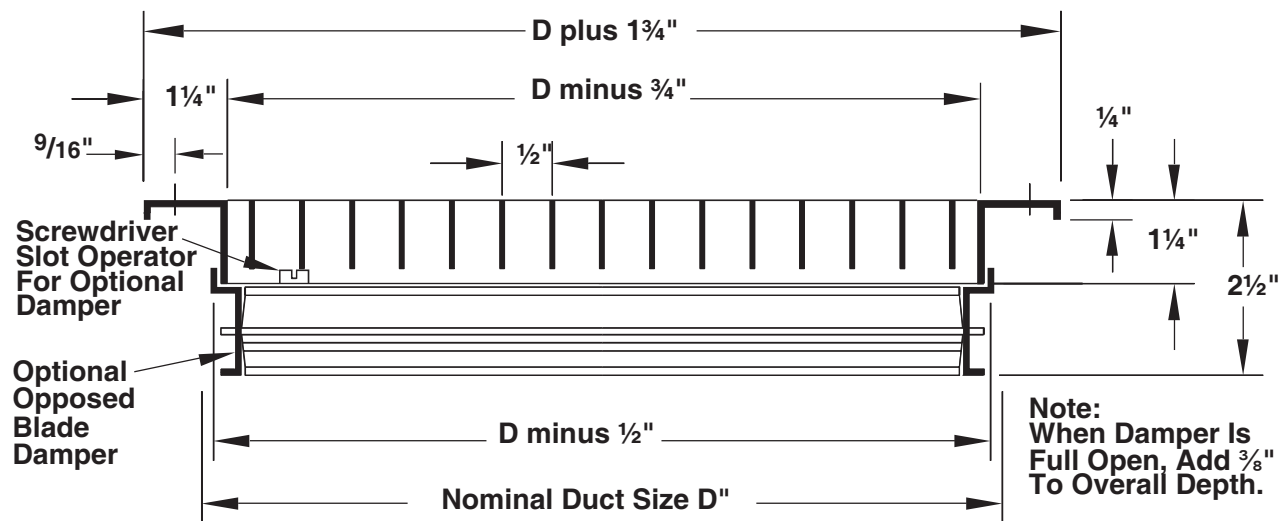

Available sizes (D" x D") are 6 x 4 inches through 48 x 48 inches in 1" increments
Odd and fractional sizes are available at additional cost

350R, 350F AND 350R-SS

PERFORMANCE BASED ON NOMINAL SIZES SHOWN IN BOLD

Nominal Duct Size (in.)	Nominal Duct Area (ft ²)	Core Area (ft ²)	Core Velocity Velocity Pressure Neg. Static Pressure	NC-20									
				100 0.001 0.002	200 0.002 0.008	300 0.006 0.018	400 0.010 0.032	500 0.016 0.051	600 0.022 0.073	700 0.031 0.099	800 0.040 0.130	900 0.050 0.164	
6x6	0.25	0.19	Airflow, cfm NC	19 -	38 -	57 -	76 -	95 -	114 13	133 19	152 25	171 29	
8x6	0.33	0.26	Airflow, cfm NC	26 -	52 -	78 -	104 -	130 -	156 15	182 20	208 26	234 30	
10x6	0.42	0.34	Airflow, cfm NC	34 -	68 -	102 -	136 -	170 -	204 16	238 21	272 28	306 32	
8x8	0.44	0.37	Airflow, cfm NC	37 -	74 -	111 -	148 -	185 -	222 16	259 22	296 28	333 32	
12x6	0.5	0.41	Airflow, cfm NC	41 -	82 -	123 -	164 -	205 -	246 17	287 22	328 30	369 34	
14x6	0.58	0.48	Airflow, cfm NC	48 -	96 -	144 -	192 -	240 -	288 18	336 24	384 30	432 34	
16x6	0.67	0.57	Airflow, cfm NC	57 -	114 -	171 -	228 -	285 10	342 19	399 25	456 30	513 35	
10x10	0.69	0.59	Airflow, cfm NC	59 -	118 -	177 -	236 -	295 10	354 19	413 25	472 31	531 35	
18x6	0.75	0.63	Airflow, cfm NC	63 -	126 -	189 -	252 -	315 10	378 19	441 25	504 32	567 35	
20x6	0.83	0.72	Airflow, cfm NC	72 -	144 -	216 -	288 -	360 11	432 19	504 25	576 30	648 35	
22x6	0.92	0.77	Airflow, cfm NC	77 -	154 -	231 -	308 -	385 11	462 19	539 25	616 30	693 35	
24x6	1	0.88	Airflow, cfm NC	88 -	176 -	264 -	352 -	440 11	528 19	616 25	704 30	792 35	
30x6	1.25	1.11	Airflow, cfm NC	111 -	222 -	333 -	444 -	555 12	666 20	777 26	888 32	999 35	
14x14	1.36	1.22	Airflow, cfm NC	122 -	244 -	366 -	488 -	610 12	732 20	854 27	976 32	1098 35	
36x6	1.5	1.35	Airflow, cfm NC	135 -	270 -	405 -	540 -	675 13	810 20	945 27	1080 32	1215 35	
22x10	1.53	1.37	Airflow, cfm NC	137 -	274 -	411 -	548 -	685 13	822 20	959 27	1096 32	1233 36	
30x8	1.67	1.49	Airflow, cfm NC	149 -	298 -	447 -	596 -	745 14	894 21	1043 27	1192 33	1341 37	
42x6	1.75	1.59	Airflow, cfm NC	159 -	318 -	477 -	636 -	795 14	954 21	1113 27	1272 33	1431 37	
16x16	1.78	1.62	Airflow, cfm NC	162 -	324 -	486 -	648 -	810 14	972 21	1134 27	1296 33	1458 37	
24x12	2	1.82	Airflow, cfm NC	182 -	364 -	546 -	728 -	910 14	1092 21	1274 28	1456 33	1638 38	
18x18	2.25	2.07	Airflow, cfm NC	207 -	414 -	621 -	828 -	1035 14	1242 21	1449 28	1656 33	1863 38	
24x14	2.33	2.14	Airflow, cfm NC	214 -	428 -	642 -	856 -	1070 14	1284 22	1498 28	1712 33	1926 38	
30x12	2.5	2.29	Airflow, cfm NC	229 -	458 -	687 -	916 -	1145 15	1374 22	1603 28	1832 33	2061 38	
24x16	2.67	2.46	Airflow, cfm NC	246 -	492 -	738 -	984 -	1230 15	1476 22	1722 29	1968 34	2214 39	
20x20	2.78	2.57	Airflow, cfm NC	257 -	514 -	771 -	1028 -	1285 16	1542 23	1799 29	2056 34	2313 39	
36x12	3	2.75	Airflow, cfm NC	275 -	550 -	825 -	1100 -	1375 16	1650 23	1925 29	2200 34	2475 39	
30x16	3.33	3.11	Airflow, cfm NC	311 -	622 -	933 -	1244 -	1555 17	1866 24	2177 30	2488 35	2799 40	
22x22	3.36	3.14	Airflow, cfm NC	314 -	628 -	942 -	1256 -	1570 17	1884 24	2198 30	2512 35	2826 40	
42x12	3.5	3.22	Airflow, cfm NC	322 -	644 -	966 -	1288 -	1610 17	1932 24	2254 30	2576 36	2898 40	
24x22	3.67	3.43	Airflow, cfm NC	343 -	686 -	1029 -	1372 -	1715 17	2058 24	2401 30	2744 36	3087 40	
30x18	3.75	3.5	Airflow, cfm NC	350 -	700 -	1050 -	1400 -	1750 17	2100 24	2450 30	2800 36	3150 40	

• Static pressures are negative, in inches of water, measured per ANSI/ASHRAE Standard 70-2006

• NC based on room absorption of 10 dB, re 10⁻¹² watts, measured per ANSI/ASHRAE Standard 70-2006

PERFORMANCE DATA

300 / 350 grilles

350R, 350F AND 350R-SS
PERFORMANCE BASED ON NOMINAL SIZES SHOWN IN BOLD

Redefine your comfort zone™ | www.titus-hvac.com

Nominal Duct Size (in.)	Nominal Duct Area (ft ²)	Core Area (ft ²)	Core Velocity Velocity Pressure Neg. Static Pressure	NC-20 NC-30 NC-40									
				100 0.001 0.002	200 0.002 0.008	300 0.006 0.018	400 0.010 0.032	500 0.016 0.051	600 0.022 0.073	700 0.031 0.099	800 0.040 0.130	900 0.050 0.164	
48x12 24x24	4	3.75	Airflow, cfm NC	375 -	750 -	1125 -	1500 -	1875 18	2250 25	2625 37	3000 38	3375 41	
36x18	4.5	4.22	Airflow, cfm NC	422 -	844 -	1266 -	1688 -	2110 18	2532 25	2954 31	3376 38	3798 41	
36x20 30x24	5	4.71	Airflow, cfm NC	471 -	942 -	1413 -	1884 -	2355 18	2826 25	3297 31	3768 38	4239 41	
42x18	5.25	4.94	Airflow, cfm NC	494 -	988 -	1482 -	1976 -	2470 18	2964 25	3458 31	3952 38	4446 41	
28x28	5.44	5.16	Airflow, cfm NC	516 -	1032 -	1548 -	2064 -	2580 18	3096 25	3612 32	4128 38	4644 41	
42x20 30x28	5.83	5.51	Airflow, cfm NC	551 -	1102 -	1653 -	2204 10	2755 18	3306 26	3857 32	4408 38	4959 41	
48x18 36x24	6	5.66	Airflow, cfm NC	566 -	1132 -	1698 -	2264 10	2830 18	3396 26	3962 32	4528 38	5094 41	
30x30	6.25	5.94	Airflow, cfm NC	594 -	1188 -	1782 -	2376 10	2970 18	3564 26	4158 32	4752 38	5346 41	
42x24 36x28	7	6.66	Airflow, cfm NC	666 -	1332 -	1998 -	2664 10	3330 19	3996 26	4662 32	5328 38	5994 41	
46x22	7.03	6.68	Airflow, cfm NC	668 -	1336 -	2004 -	2672 10	3340 19	4008 27	4676 32	5344 38	6012 42	
32x32	7.11	6.78	Airflow, cfm NC	678 -	1356 -	2034 -	2712 10	3390 19	4068 27	4746 32	5424 38	6102 42	
36x30	7.5	7.16	Airflow, cfm NC	716 -	1432 -	2148 -	2864 10	3580 19	4296 27	5012 32	5728 38	6444 42	
48x24 36x32	8	7.63	Airflow, cfm NC	763 -	1526 -	2289 -	3052 10	3815 19	4578 27	5341 32	6104 38	6867 42	
34x34	8.03	7.68	Airflow, cfm NC	768 -	1536 -	2304 -	3072 10	3840 19	4608 27	5376 32	6144 38	6912 42	
36x34	8.5	8.14	Airflow, cfm NC	814 -	1628 -	2442 -	3256 11	4070 19	4884 27	5698 32	6512 38	7326 42	
42x30	8.75	8.38	Airflow, cfm NC	838 -	1676 -	2514 -	3352 11	4190 20	5028 27	5866 32	6704 38	7542 42	
36x36	9	8.63	Airflow, cfm NC	863 -	1726 -	2589 -	3452 11	4315 20	5178 27	6041 33	6904 38	7767 43	
42x34 48x30	10	9.6	Airflow, cfm NC	960 -	1920 -	2880 -	3840 11	4800 20	5760 27	6720 33	7680 38	8640 43	
38x38	10.03	9.64	Airflow, cfm NC	964 -	1928 -	2892 -	3856 11	4820 20	5784 27	6748 33	7712 38	8676 43	
42x36	10.5	10.1	Airflow, cfm NC	1010 -	2020 -	3030 -	4040 11	5050 20	6060 27	7070 33	8080 38	9090 43	
46x34	10.86	10.45	Airflow, cfm NC	1045 -	2090 -	3135 -	4180 11	5225 20	6270 27	7315 33	8360 38	9405 43	
42x38	11.08	10.67	Airflow, cfm NC	1067 -	2134 -	3201 -	4268 11	5335 20	6402 27	7469 33	8536 38	9603 43	
40x40	11.11	10.7	Airflow, cfm NC	1070 -	2140 -	3210 -	4280 11	5350 20	6420 27	7490 33	8560 38	9630 43	
48x36	12	11.57	Airflow, cfm NC	1157 -	2314 -	3471 -	4628 11	5785 20	6942 27	8099 33	9256 39	10413 44	
42x42	12.25	11.82	Airflow, cfm NC	1182 -	2364 -	3546 -	4728 11	5910 20	7092 27	8274 33	9456 39	10638 44	
44x44	13.44	12.99	Airflow, cfm NC	1299 -	2598 -	3897 -	5196 12	6495 21	7794 28	9093 34	10392 39	11691 44	
48x42	14	13.54	Airflow, cfm NC	1354 -	2708 -	4062 -	5416 12	6770 21	8124 28	9478 34	10832 40	12186 45	
46x46	14.69	14.22	Airflow, cfm NC	1422 -	2844 -	4266 -	5688 12	7110 21	8532 28	9954 35	11376 40	12798 45	
48x46	15.33	14.85	Airflow, cfm NC	1485 -	2970 -	4455 -	5940 12	7425 22	8910 28	10395 35	11880 40	13365 45	
48x48	16	15.5	Airflow, cfm NC	1550 -	3100 -	4650 -	6200 13	7750 22	9300 29	10850 35	12400 40	13950 45	

• Static pressures are negative, in inches of water, measured per ANSI/ASHRAE Standard 70-2006

• NC based on room absorption of 10 dB, re 10⁻¹² watts, measured per ANSI/ASHRAE Standard 70-2006



PERFORMANCE DATA

300 / 350 grilles

350ZR AND 350ZF

PERFORMANCE BASED ON NOMINAL SIZES SHOWN IN BOLD

Nominal Duct Size (in.)	Nominal Duct Area (ft ²)	Core Area (ft ²)	Core Velocity Velocity Pressure Neg. Static Pressure	300		400		500		600		700		900		1100		1300		1500	
				0.006 0.012	0.010 0.022	0.016 0.034	0.022 0.049	0.031 0.067	0.050 0.111	0.075 0.165	0.105 0.231	0.140 0.307	NC-10	NC-20	NC-30	NC-40					
6x6	0.25	0.19	Airflow, cfm NC	57 -	76 -	95 -	114 -	133 13	171 20	209 26	247 31	285 35									
8x6	0.33	0.26	Airflow, cfm NC	78 -	104 -	130 -	156 -	182 14	234 22	286 27	338 32	390 36									
10x6	0.42	0.34	Airflow, cfm NC	102 -	136 -	170 -	204 11	238 16	306 23	374 28	442 33	510 37									
8x8	0.44	0.37	Airflow, cfm NC	111 -	148 -	185 -	222 12	259 16	333 23	407 29	481 34	555 38									
12x6	0.5	0.41	Airflow, cfm NC	123 -	164 -	205 -	246 12	287 16	369 24	451 29	533 34	615 38									
14x6	0.58	0.48	Airflow, cfm NC	144 -	192 -	240 -	288 13	336 17	432 24	528 30	624 35	720 39									
16x6			Airflow, cfm	171	228	285	342	399	513	627	741	855									
12x8	0.67	0.57	NC	-	-	-	13	18	25	31	36	40									
10x10	0.69	0.59	Airflow, cfm NC	177 -	236 -	295 -	354 14	413 18	531 25	649 31	767 36	885 40									
18x6	0.75	0.63	Airflow, cfm NC	189 -	252 -	315 -	378 14	441 18	567 25	693 31	819 36	945 40									
20x6			Airflow, cfm	216	288	360	432	504	648	792	936	1080									
12x10	0.83	0.72	NC	-	-	-	14	19	26	32	37	41									
22x6	0.92	0.77	Airflow, cfm NC	231 -	308 -	385 -	462 15	539 19	693 26	847 32	1001 37	1155 41									
24x6			Airflow, cfm	264	352	440	528	616	792	968	1144	1320									
12x12	1	0.88	NC	-	-	-	15	20	27	33	37	42									
30x6			Airflow, cfm	333	444	555	666	777	999	1221	1443	1665									
18x10	1.25	1.11	NC	-	-	-	16	21	28	34	38	43									
14x14	1.36	1.22	Airflow, cfm NC	366 -	488 -	610 11	732 17	854 21	1098 28	1342 34	1586 39	1830 43									
36x6			Airflow, cfm	405	540	675	810	945	1215	1485	1755	2025									
18x12	1.5	1.35	NC	-	-	-	12	17	22	29	35	43									
22x10	1.53	1.37	Airflow, cfm NC	411 -	548 -	685 12	822 17	959 22	1233 29	1507 35	1781 39	2055 43									
30x8			Airflow, cfm	447	596	745	894	1043	1341	1639	1937	2235									
24x10	1.67	1.49	NC	-	-	-	12	18	22	29	35	44									
42x6			Airflow, cfm	477	636	795	954	1113	1431	1749	2067	2385									
18x14	1.75	1.59	NC	-	-	-	13	18	22	29	35	44									
16x16	1.78	1.62	Airflow, cfm NC	486 -	648 -	810 13	972 18	1134 22	1458 30	1782 35	2106 40	2430 44									
24x12	2	1.82	Airflow, cfm NC	546 -	728 -	910 13	1092 18	1274 23	1638 30	2002 36	2366 41	2730 45									
18x18	2.25	2.07	Airflow, cfm NC	621 -	828 -	1035 14	1242 19	1449 23	1863 31	2277 36	2691 41	3105 45									
24x14	2.33	2.14	Airflow, cfm NC	642 -	856 -	1070 14	1284 19	1498 24	1926 31	2354 37	2782 41	3210 45									
30x12	2.5	2.29	Airflow, cfm NC	687 -	916 -	1145 14	1374 19	1603 24	2061 31	2519 37	2977 42	3435 46									
24x16	2.67	2.46	Airflow, cfm NC	738 -	984 -	1230 15	1476 20	1722 24	2214 31	2706 37	3198 42	3690 46									
20x20	2.78	2.57	Airflow, cfm NC	771 -	1028 -	1285 15	1542 20	1799 24	2313 32	2827 37	3341 42	3855 46									
36x12	3	2.75	Airflow, cfm NC	825 -	1100 -	1375 15	1650 20	1925 25	2475 32	3025 38	3575 42	4125 47									
30x16	3.33	3.11	Airflow, cfm	933	1244	1555	1866	2177	2799	3421	4043	4665									
24x20			NC	-	-	-	16	21	25	32	38	47									
22x22	3.36	3.14	Airflow, cfm NC	942 -	1256 -	1570 16	1884 21	2198 25	2826 32	3454 38	4082 43	4710 47									
42x12			Airflow, cfm	966	1288	1610	1932	2254	2898	3542	4186	4830									
36x14	3.5	3.22	NC	-	-	-	16	21	25	33	43	47									
24x22	3.67	3.43	Airflow, cfm NC	1029 -	1372 -	1715 16	2058 21	2401 26	3087 33	3773 39	4459 43	5145 47									
30x18	3.75	3.5	Airflow, cfm NC	1050 -	1400 -	1750 16	2100 21	2450 26	3150 33	3850 39	4550 43	5250 48									

• Static pressures are negative, in inches of water, measured per ANSI/ASHRAE Standard 70-2006

• NC based on room absorption of 10 dB, re 10⁻¹² watts, measured per ANSI/ASHRAE Standard 70-2006

350ZR AND 350ZF
PERFORMANCE BASED ON NOMINAL SIZES SHOWN IN BOLD

Nominal Duct Size (in.)	Nominal Duct Area (ft ²)	Core Area (ft ²)	Core Velocity Velocity Pressure Neg. Static Pressure	NC-10		NC-20		NC-30		NC-40		
				300 0.006 0.012	400 0.010 0.022	500 0.016 0.034	600 0.022 0.049	700 0.031 0.067	900 0.050 0.111	1100 0.075 0.165	1300 0.105 0.231	1500 0.140 0.307
48x12 24x24	4	3.75	Airflow, cfm NC	1125 -	1500 -	1875 16	2250 22	2625 26	3375 33	4125 39	4875 44	5625 48
36x18	4.5	4.22	Airflow, cfm NC	1266 -	1688 -	2110 17	2532 22	2954 27	3798 34	4642 39	5486 44	6330 48
36x20 30x24	5	4.71	Airflow, cfm NC	1413 -	1884 11	2355 17	2826 23	3297 27	4239 34	5181 40	6123 45	7065 49
42x18	5.25	4.94	Airflow, cfm NC	1482 -	1976 11	2470 18	2964 23	3458 27	4446 34	5434 40	6422 45	7410 49
28x28	5.44	5.16	Airflow, cfm NC	1548 -	2064 11	2580 18	3096 23	3612 27	4644 35	5676 40	6708 45	7740 49
42x20 30x28	5.83	5.51	Airflow, cfm NC	1653 -	2204 12	2755 18	3306 23	3857 28	4959 35	6061 41	7163 45	8265 50
48x18 36x24	6	5.66	Airflow, cfm NC	1698 -	2264 12	2830 18	3396 23	3962 28	5094 35	6226 41	7358 46	8490 50
30x30	6.25	5.94	Airflow, cfm NC	1782 -	2376 12	2970 18	3564 24	4158 28	5346 35	6534 41	7722 46	8910 50
42x24 36x28	7	6.66	Airflow, cfm NC	1998 -	2664 12	3330 19	3996 24	4662 28	5994 36	7326 41	8658 46	9990 50
46x22	7.03	6.68	Airflow, cfm NC	2004 -	2672 12	3340 19	4008 24	4676 29	6012 36	7348 41	8684 46	10020 50
32x32	7.11	6.78	Airflow, cfm NC	2034 -	2712 13	3390 19	4068 24	4746 29	6102 36	7458 42	8814 46	10170 50
36x30 48x24 36x32	7.5	7.16	Airflow, cfm NC	2148 -	2864 13	3580 19	4296 24	5012 29	6444 36	7876 42	9308 47	10740 51
48x24 36x32	8	7.63	Airflow, cfm NC	2289 -	3052 13	3815 19	4578 25	5341 29	6867 36	8393 42	9919 47	11445 51
34x34	8.03	7.68	Airflow, cfm NC	2304 -	3072 13	3840 19	4608 25	5376 29	6912 36	8448 42	9984 47	11520 51
36x34	8.5	8.14	Airflow, cfm NC	2442 -	3256 13	4070 20	4884 25	5698 29	7326 37	8954 42	10582 47	12210 51
42x30	8.75	8.38	Airflow, cfm NC	2514 -	3352 13	4190 20	5028 25	5866 29	7542 37	9218 42	10894 47	12570 51
36x36	9	8.63	Airflow, cfm NC	2589 -	3452 14	4315 20	5178 25	6041 30	7767 37	9493 43	11219 47	12945 51
42x34 48x30	10	9.6	Airflow, cfm NC	2880 -	3840 14	4800 20	5760 26	6720 30	8640 37	10560 43	12480 48	14400 52
38x38	10.03	9.64	Airflow, cfm NC	2892 -	3856 14	4820 20	5784 26	6748 30	8676 37	10604 43	12532 48	14460 52
42x36	10.5	10.1	Airflow, cfm NC	3030 -	4040 14	5050 21	6060 26	7070 30	9090 38	11110 43	13130 48	15150 52
46x34	10.86	10.45	Airflow, cfm NC	3135 -	4180 14	5225 21	6270 26	7315 30	9405 38	11495 43	13585 48	15675 52
42x38	11.08	10.67	Airflow, cfm NC	3201 -	4268 14	5335 21	6402 26	7469 31	9603 38	11737 44	13871 48	16005 52
40x40	11.11	10.7	Airflow, cfm NC	3210 -	4280 15	5350 21	6420 26	7490 31	9630 38	11770 44	13910 48	16050 52
48x36	12	11.57	Airflow, cfm NC	3471 -	4628 15	5785 21	6942 26	8099 31	10413 38	12727 44	15041 49	17355 53
42x42	12.25	11.82	Airflow, cfm NC	3546 -	4728 15	5910 21	7092 27	8274 31	10638 38	13002 44	15366 49	17730 53
44x44	13.44	12.99	Airflow, cfm NC	3897 -	5196 15	6495 22	7794 27	9093 31	11691 39	14289 44	16887 49	19485 53
48x42	14	13.54	Airflow, cfm NC	4062 -	5416 16	6770 22	8124 27	9478 32	12186 39	14894 45	17602 49	20310 53
46x46	14.69	14.22	Airflow, cfm NC	4266 -	5688 16	7110 22	8532 27	9954 32	12798 39	15642 45	18486 50	21330 54
48x46	15.33	14.85	Airflow, cfm NC	4455 -	5940 16	7425 22	8910 28	10395 32	13365 39	16335 45	19305 50	22275 54
48x48	16	15.5	Airflow, cfm NC	4650 -	6200 16	7750 23	9300 28	10850 32	13950 39	17050 45	20150 50	23250 54

NC-50

- Static pressures are negative, in inches of water, measured per ANSI/ASHRAE Standard 70-2006
- NC based on room absorption of 10 dB, re 10⁻¹² watts, measured per ANSI/ASHRAE Standard 70-2006

355R AND 355F

PERFORMANCE BASED ON NOMINAL SIZES SHOWN IN BOLD

Nominal Duct Size (in.)	Nominal Duct Area (ft ²)	Core Area (ft ²)	Core Velocity Velocity Pressure Neg. Static Pressure	NC-20						NC-30		
				100 0.001 0.003	200 0.002 0.011	300 0.006 0.026	400 0.010 0.045	500 0.016 0.071	600 0.022 0.102	700 0.031 0.139	800 0.040 0.182	900 0.050 0.230
6x6	0.25	0.19	Airflow, cfm	19	38	57	76	95	114	133	152	171
			NC	-	-	-	-	10	18	25	29	33
8x6	0.33	0.26	Airflow, cfm	26	52	78	104	130	156	182	208	234
			NC	-	-	-	-	11	19	25	30	35
10x6	0.42	0.34	Airflow, cfm	34	68	102	136	170	204	238	272	306
			NC	-	-	-	-	12	20	26	31	36
8x8	0.44	0.37	Airflow, cfm	37	74	111	148	185	222	259	296	333
			NC	-	-	-	-	12	20	26	31	36
12x6	0.5	0.41	Airflow, cfm	41	82	123	164	205	246	287	328	369
			NC	-	-	-	-	12	20	26	32	36
14x6	0.58	0.48	Airflow, cfm	48	96	144	192	240	288	336	384	432
			NC	-	-	-	-	12	20	26	32	37
16x6			Airflow, cfm	57	114	171	228	285	342	399	456	513
			NC	-	-	-	-	13	21	27	32	38
10x10	0.69	0.59	Airflow, cfm	59	118	177	236	295	354	413	472	531
			NC	-	-	-	-	13	21	27	32	38
18x6	0.75	0.63	Airflow, cfm	63	126	189	252	315	378	441	504	567
			NC	-	-	-	-	14	22	28	33	38
20x6			Airflow, cfm	72	144	216	288	360	432	504	576	648
			NC	-	-	-	-	14	22	28	33	38
22x6	0.92	0.77	Airflow, cfm	77	154	231	308	385	462	539	616	693
			NC	-	-	-	-	14	22	28	34	38
24x6			Airflow, cfm	88	176	264	352	440	528	616	704	792
			NC	-	-	-	-	15	22	28	34	39
30x6			Airflow, cfm	111	222	333	444	555	666	777	888	999
			NC	-	-	-	-	15	22	28	34	39
14x14	1.36	1.22	Airflow, cfm	122	244	366	488	610	732	854	976	1098
			NC	-	-	-	-	16	23	29	34	39
36x6			Airflow, cfm	135	270	405	540	675	810	945	1080	1215
			NC	-	-	-	-	16	24	29	34	39
22x10	1.53	1.37	Airflow, cfm	137	274	411	548	685	822	959	1096	1233
			NC	-	-	-	-	16	24	30	35	39
30x8			Airflow, cfm	149	298	447	596	745	894	1043	1192	1341
			NC	-	-	-	-	16	24	30	35	39
42x6			Airflow, cfm	159	318	477	636	795	954	1113	1272	1431
			NC	-	-	-	-	17	24	30	35	39
18x14	1.75	1.59	Airflow, cfm	162	324	486	648	810	972	1134	1296	1458
			NC	-	-	-	-	17	24	30	35	39
24x12	2	1.82	Airflow, cfm	182	364	546	728	910	1092	1274	1456	1638
			NC	-	-	-	-	17	24	30	35	39
18x18	2.25	2.07	Airflow, cfm	207	414	621	828	1035	1242	1449	1656	1863
			NC	-	-	-	-	18	25	31	35	40
24x14	2.33	2.14	Airflow, cfm	214	428	642	856	1070	1284	1498	1712	1926
			NC	-	-	-	-	18	25	31	35	40
30x12	2.5	2.29	Airflow, cfm	229	458	687	916	1145	1374	1603	1832	2061
			NC	-	-	-	-	18	25	31	35	40
24x16	2.67	2.46	Airflow, cfm	246	492	738	984	1230	1476	1722	1968	2214
			NC	-	-	-	-	18	25	32	36	39
20x20	2.78	2.57	Airflow, cfm	257	514	771	1028	1285	1542	1799	2056	2313
			NC	-	-	-	-	18	25	32	36	40
36x12	3	2.75	Airflow, cfm	275	550	825	1100	1375	1650	1925	2200	2475
			NC	-	-	-	-	19	26	32	37	42
30x16	3.33	3.11	Airflow, cfm	311	622	933	1244	1555	1866	2177	2488	2799
			NC	-	-	-	-	19	26	32	37	42
22x22	3.36	3.14	Airflow, cfm	314	628	942	1256	1570	1884	2198	2512	2826
			NC	-	-	-	-	19	26	33	38	42
42x12			Airflow, cfm	322	644	966	1288	1610	1932	2254	2576	2898
			NC	-	-	-	-	19	26	33	38	43
36x14	3.5	3.22	Airflow, cfm	343	686	1029	1372	1715	2058	2401	2744	3087
			NC	-	-	-	-	19	26	33	38	43
24x22	3.67	3.43	Airflow, cfm	350	700	1050	1400	1750	2100	2450	2800	3150
			NC	-	-	-	-	19	26	33	38	43

NC-40

• Static pressures are negative, in inches of water, measured per ANSI/ASHRAE Standard 70-2006

• NC based on room absorption of 10 dB, re 10⁻¹² watts, measured per ANSI/ASHRAE Standard 70-2006

PERFORMANCE DATA

355R AND 355F

PERFORMANCE BASED ON NOMINAL SIZES SHOWN IN BOLD

Nominal Duct Size (in.)	Nominal Duct Area (ft ²)	Core Area (ft ²)	Core Velocity Velocity Pressure Neg. Static Pressure	NC-20 NC-30 NC-40								
				100 0.001 0.003	200 0.002 0.011	300 0.006 0.026	400 0.010 0.045	500 0.016 0.071	600 0.022 0.102	700 0.031 0.139	800 0.040 0.182	900 0.050 0.230
48x12 24x24	4	3.75	Airflow, cfm NC	375 -	750 -	1125 -	1500 10	1875 19	2250 26	2625 33	3000 39	3375 43
36x18	4.5	4.22	Airflow, cfm NC	422 -	844 -	1266 -	1688 10	2110 19	2532 26	2954 33	3376 39	3798 43
36x20 30x24	5	4.71	Airflow, cfm NC	471 -	942 -	1413 -	1884 11	2355 19	2826 27	3297 33	3768 38	4239 43
42x18	5.25	4.94	Airflow, cfm NC	494 -	988 -	1482 -	1976 12	2470 20	2964 28	3458 34	3952 39	4446 44
28x28	5.44	5.16	Airflow, cfm NC	516 -	1032 -	1548 -	2064 12	2580 21	3096 28	3612 34	4128 40	4644 44
42x20 30x28	5.83	5.51	Airflow, cfm NC	551 -	1102 -	1653 -	2204 12	2755 21	3306 28	3857 34	4408 40	4959 44
48x18 36x24	6	5.66	Airflow, cfm NC	566 -	1132 -	1698 -	2264 12	2830 21	3396 28	3962 35	4528 40	5094 44
30x30	6.25	5.94	Airflow, cfm NC	594 -	1188 -	1782 -	2376 12	2970 21	3564 28	4158 35	4752 40	5346 44
42x24 36x28	7	6.66	Airflow, cfm NC	666 -	1332 -	1998 -	2664 13	3330 22	3996 29	4662 35	5328 40	5994 45
46x22	7.03	6.68	Airflow, cfm NC	668 -	1336 -	2004 -	2672 13	3340 22	4008 29	4676 35	5344 40	6012 45
32x32	7.11	6.78	Airflow, cfm NC	678 -	1356 -	2034 -	2712 13	3390 22	4068 29	4746 35	5424 40	6102 45
36x30	7.5	7.16	Airflow, cfm NC	716 -	1432 -	2148 -	2864 14	3580 23	4296 30	5012 36	5728 41	6444 46
48x24 36x32	8	7.63	Airflow, cfm NC	763 -	1526 -	2289 -	3052 14	3815 23	4578 30	5341 36	6104 41	6867 46
34x34	8.03	7.68	Airflow, cfm NC	768 -	1536 -	2304 -	3072 14	3840 23	4608 30	5376 36	6144 41	6912 46
36x34	8.5	8.14	Airflow, cfm NC	814 -	1628 -	2442 -	3256 14	4070 23	4884 30	5698 36	6512 41	7326 46
42x30	8.75	8.38	Airflow, cfm NC	838 -	1676 -	2514 -	3352 14	4190 23	5028 30	5866 36	6704 41	7542 46
36x36	9	8.63	Airflow, cfm NC	863 -	1726 -	2589 -	3452 14	4315 23	5178 30	6041 36	6904 41	7767 46
42x34 48x30	10	9.6	Airflow, cfm NC	960 -	1920 -	2880 -	3840 14	4800 23	5760 30	6720 36	7680 41	8640 46
38x38	10.03	9.64	Airflow, cfm NC	964 -	1928 -	2892 -	3856 14	4820 23	5784 30	6748 36	7712 41	8676 46
42x36	10.5	10.1	Airflow, cfm NC	1010 -	2020 -	3030 -	4040 15	5050 23	6060 31	7070 37	8080 42	9090 47
46x34	10.86	10.45	Airflow, cfm NC	1045 -	2090 -	3135 -	4180 15	5225 23	6270 31	7315 37	8360 42	9405 47
42x38	11.08	10.67	Airflow, cfm NC	1067 -	2134 -	3201 -	4268 15	5335 23	6402 31	7469 37	8536 42	9603 47
40x40	11.11	10.7	Airflow, cfm NC	1070 -	2140 -	3210 -	4280 15	5350 23	6420 31	7490 37	8560 42	9630 47
48x36	12	11.57	Airflow, cfm NC	1157 -	2314 -	3471 -	4628 15	5785 23	6942 31	8099 37	9256 42	10413 47
42x42	12.25	11.82	Airflow, cfm NC	1182 -	2364 -	3546 -	4728 15	5910 24	7092 31	8274 37	9456 42	10638 47
44x44	13.44	12.99	Airflow, cfm NC	1299 -	2598 -	3897 -	5196 15	6495 24	7794 32	9093 38	10392 43	11691 48
48x42	14	13.54	Airflow, cfm NC	1354 -	2708 -	4062 -	5416 16	6770 24	8124 32	9478 38	10832 43	12186 48
46x46	14.69	14.22	Airflow, cfm NC	1422 -	2844 -	4266 -	5688 16	7110 25	8532 32	9954 39	11376 44	12798 48
48x46	15.33	14.85	Airflow, cfm NC	1485 -	2970 -	4455 -	5940 16	7425 25	8910 32	10395 39	11880 44	13365 48
48x48	16	15.5	Airflow, cfm NC	1550 -	3100 -	4650 -	6200 16	7750 25	9300 32	10850 39	12400 44	13950 48

• Static pressures are negative, in inches of water, measured per ANSI/ASHRAE Standard 70-2006

• NC based on room absorption of 10 dB, re 10⁻¹² watts, measured per ANSI/ASHRAE Standard 70-2006

PERFORMANCE DATA

300 / 350 grilles

355ZR AND 355ZF

PERFORMANCE BASED ON NOMINAL SIZES SHOWN IN BOLD

Nominal Duct Size (in.)	Nominal Duct Area (ft ²)	Core Area (ft ²)	Core Velocity Velocity Pressure Neg. Static Pressure	NC-10			NC-20			NC-30		
				300 0.006 0.013	400 0.010 0.022	500 0.016 0.035	600 0.022 0.050	700 0.031 0.068	800 0.040 0.089	900 0.050 0.113	1000 0.062 0.140	1100 0.075 0.169
6x6	0.25	0.19	Airflow, cfm NC	57 -	76 -	95 -	114 12	133 16	152 20	171 23	190 25	209 28
8x6	0.33	0.26	Airflow, cfm NC	78 -	104 -	130 -	156 13	182 17	208 21	234 24	260 27	286 29
10x6	0.42	0.34	Airflow, cfm NC	102 -	136 -	170 -	204 15	238 19	272 22	306 24	340 28	374 31
8x8	0.44	0.37	Airflow, cfm NC	111 -	148 -	185 -	222 15	259 19	296 23	333 26	370 28	407 31
12x6	0.5	0.41	Airflow, cfm NC	123 -	164 -	205 11	246 15	287 19	328 23	369 26	410 29	451 31
14x6	0.58	0.48	Airflow, cfm NC	144 -	192 -	240 11	288 16	336 20	384 24	432 27	480 30	528 32
16x6 12x8	0.67	0.57	Airflow, cfm NC	171 -	228 -	285 12	342 17	399 21	456 24	513 27	570 30	627 33
10x10	0.69	0.59	Airflow, cfm NC	177 -	236 -	295 12	354 17	413 21	472 25	531 28	590 30	649 33
18x6	0.75	0.63	Airflow, cfm NC	189 -	252 -	315 12	378 17	441 21	504 25	567 28	630 31	693 33
20x6 12x10	0.83	0.72	Airflow, cfm NC	216 -	288 -	360 13	432 18	504 22	576 25	648 29	720 31	792 34
22x6	0.92	0.77	Airflow, cfm NC	231 -	308 -	385 13	462 18	539 22	616 26	693 29	770 32	847 34
24x6 12x12	1	0.88	Airflow, cfm NC	264 -	352 -	440 14	528 19	616 23	704 26	792 29	880 32	968 35
30x6 18x10	1.25	1.11	Airflow, cfm NC	333 -	444 -	555 15	666 20	777 24	888 27	999 30	1110 33	1221 36
14x14	1.36	1.22	Airflow, cfm NC	366 -	488 -	610 15	732 20	854 24	976 28	1098 31	1220 34	1342 36
36x6 18x12	1.5	1.35	Airflow, cfm NC	405 -	540 -	675 16	810 21	945 25	1080 28	1215 31	1350 34	1485 37
22x10	1.53	1.37	Airflow, cfm NC	411 -	548 -	685 16	822 21	959 25	1096 28	1233 31	1370 34	1507 37
30x8 24x10	1.67	1.49	Airflow, cfm NC	447 -	596 -	745 16	894 21	1043 25	1192 29	1341 32	1490 34	1639 37
42x6 18x14	1.75	1.59	Airflow, cfm NC	477 -	636 11	795 17	954 21	1113 25	1272 29	1431 32	1590 35	1749 37
16x16	1.78	1.62	Airflow, cfm NC	486 -	648 11	810 17	972 21	1134 25	1296 29	1458 32	1620 35	1782 37
24x12 18x16	2	1.82	Airflow, cfm NC	546 -	728 11	910 17	1092 22	1274 26	1456 29	1638 33	1820 35	2002 38
18x18	2.25	2.07	Airflow, cfm NC	621 -	828 12	1035 18	1242 22	1449 26	1656 30	1863 33	2070 36	2277 38
24x14	2.33	2.14	Airflow, cfm NC	642 -	856 12	1070 18	1284 23	1498 27	1712 30	1926 33	2140 36	2354 39
30x12	2.5	2.29	Airflow, cfm NC	687 -	916 12	1145 18	1374 23	1603 27	1832 30	2061 34	2290 36	2519 39
24x16	2.67	2.46	Airflow, cfm NC	738 -	984 13	1230 18	1476 23	1722 27	1968 31	2214 34	2460 37	2706 39
20x20	2.78	2.57	Airflow, cfm NC	771 -	1028 13	1285 19	1542 23	1799 27	2056 31	2313 34	2570 37	2827 39
36x12	3	2.75	Airflow, cfm NC	825 -	1100 13	1375 19	1650 24	1925 28	2200 31	2475 34	2750 37	3025 40
30x16 24x20	3.33	3.11	Airflow, cfm NC	933 -	1244 14	1555 19	1866 24	2177 28	2488 32	2799 35	3110 38	3421 40
22x22	3.36	3.14	Airflow, cfm NC	942 -	1256 14	1570 19	1884 24	2198 28	2512 32	2826 35	3140 38	3454 40
42x12 36x14	3.5	3.22	Airflow, cfm NC	966 -	1288 14	1610 20	1932 24	2254 28	2576 32	2898 35	3220 38	3542 40
24x22	3.67	3.43	Airflow, cfm NC	1029 -	1372 14	1715 20	2058 25	2401 29	2744 32	3087 35	3430 38	3773 41
30x18	3.75	3.5	Airflow, cfm NC	1050 -	1400 14	1750 20	2100 25	2450 29	2800 32	3150 35	3500 38	3850 41

NC-40

- Static pressures are negative, in inches of water, measured per ANSI/ASHRAE Standard 70-2006.
- NC based on room absorption of 10 dB, re 10⁻¹² watts, measured per ANSI/ASHRAE Standard 70-2006.

355ZR AND 355ZF
PERFORMANCE BASED ON NOMINAL SIZES SHOWN IN BOLD

Nominal Duct Size (in.)	Nominal Duct Area (ft ²)	Core Area (ft ²)	Core Velocity Velocity Pressure Neg. Static Pressure	NC-10		NC-20		NC-30			NC-40		
				300 0.006 0.013	400 0.010 0.022	500 0.016 0.035	600 0.022 0.050	700 0.031 0.068	800 0.040 0.089	900 0.050 0.113	1000 0.062 0.140	1100 0.075 0.169	
42x18	5.25	4.94	Airflow, cfm NC	1482 -	1976 16	2470 21	2964 26	3458 30	3952 34	4446 37	4940 40	5434 42	
28x28	5.44	5.16	Airflow, cfm NC	1548 -	2064 16	2580 22	3096 26	3612 30	4128 34	4644 37	5160 40	5676 42	
42x20 30x28	5.83	5.51	Airflow, cfm NC	1653 -	2204 16	2755 22	3306 27	3857 31	4408 34	4959 37	5510 40	6061 43	
48x18 36x24	6	5.66	Airflow, cfm NC	1698 -	2264 16	2830 22	3396 27	3962 31	4528 34	5094 37	5660 40	6226 43	
30x30	6.25	5.94	Airflow, cfm NC	1782 -	2376 16	2970 22	3564 27	4158 31	4752 35	5346 38	5940 40	6534 43	
42x24 36x28	7	6.66	Airflow, cfm NC	1998 -	2664 17	3330 23	3996 28	4662 32	5328 35	5994 38	6660 41	7326 43	
46x22	7.03	6.68	Airflow, cfm NC	2004 -	2672 17	3340 23	4008 28	4676 32	5344 35	6012 38	6680 41	7348 43	
32x32	7.11	6.78	Airflow, cfm NC	2034 -	2712 17	3390 23	4068 28	4746 32	5424 35	6102 38	6780 41	7458 44	
36x30	7.5	7.16	Airflow, cfm NC	2148 -	2864 17	3580 23	4296 28	5012 32	5728 35	6444 38	7160 41	7876 44	
48x24 36x32	8	7.63	Airflow, cfm NC	2289 -	3052 17	3815 23	4578 28	5341 32	6104 36	6867 39	7630 42	8393 44	
34x34	8.03	7.68	Airflow, cfm NC	2304 -	3072 18	3840 23	4608 28	5376 32	6144 36	6912 39	7680 42	8448 44	
36x34	8.5	8.14	Airflow, cfm NC	2442 -	3256 18	4070 24	4884 28	5698 32	6512 36	7326 39	8140 42	8954 44	
42x30	8.75	8.38	Airflow, cfm NC	2514 -	3352 18	4190 24	5028 29	5866 33	6704 36	7542 39	8380 42	9218 44	
36x36	9	8.63	Airflow, cfm NC	2589 -	3452 18	4315 24	5178 29	6041 33	6904 36	7767 39	8630 42	9493 45	
42x34 48x30	10	9.6	Airflow, cfm NC	2880 11	3840 18	4800 24	5760 29	6720 33	7680 37	8640 40	9600 43	10560 45	
38x38	10.03	9.64	Airflow, cfm NC	2892 11	3856 18	4820 24	5784 29	6748 33	7712 37	8676 40	9640 43	10604 45	
42x36	10.5	10.1	Airflow, cfm NC	3030 11	4040 19	5050 25	6060 29	7070 33	8080 37	9090 40	10100 43	11110 45	
46x34	10.86	10.45	Airflow, cfm NC	3135 11	4180 19	5225 25	6270 29	7315 34	8360 37	9405 40	10450 43	11495 45	
42x38	11.08	10.67	Airflow, cfm NC	3201 11	4268 19	5335 25	6402 30	7469 34	8536 37	9603 40	10670 43	11737 45	
40x40	11.11	10.7	Airflow, cfm NC	3210 11	4280 19	5350 25	6420 30	7490 34	8560 37	9630 40	10700 43	11770 45	
48x36	12	11.57	Airflow, cfm NC	3471 12	4628 19	5785 25	6942 30	8099 34	9256 37	10413 41	11570 43	12727 46	
42x42	12.25	11.82	Airflow, cfm NC	3546 12	4728 19	5910 25	7092 30	8274 34	9456 38	10638 41	11820 43	13002 46	
44x44	13.44	12.99	Airflow, cfm NC	3897 12	5196 20	6495 26	7794 30	9093 34	10392 38	11691 41	12990 44	14289 46	
48x42	14	13.54	Airflow, cfm NC	4062 12	5416 20	6770 26	8124 31	9478 35	10832 38	12186 41	13540 44	14894 47	
46x46	14.69	14.22	Airflow, cfm NC	4266 13	5688 20	7110 26	8532 31	9954 35	11376 38	12798 41	14220 44	15642 47	
48x46	15.33	14.85	Airflow, cfm NC	4455 13	5940 20	7425 26	8910 31	10395 35	11880 39	13365 42	14850 44	16335 47	
48x48	16	15.5	Airflow, cfm NC	4650 13	6200 21	7750 26	9300 31	10850 35	12400 39	13950 42	15500 45	17050 47	

• Static pressures are negative, in inches of water, measured per ANSI/ASHRAE Standard 70-2006

• NC based on room absorption of 10 dB, re 10⁻¹² watts, measured per ANSI/ASHRAE Standard 70-2006

Filter Return Grilles

300 / 350 grilles

350 / 355 (RLF-RSF / FLF-FSF / -SS)

Steel, Aluminum and Stainless Steel

Available Steel Models:

3/4" Spacing

- 350RLF1 / 1" Filter
- 350RSF1 / 1" Filter
- 350RLF2 / 2" Filter
- 350RSF2 / 2" Filter

1/2" Spacing

- 355RLF1 / 1" Filter
- 355RSF1 / 1" Filter
- 355RLF2 / 2" Filter
- 355RSF2 / 2" Filter

Available Aluminum Models:

3/4" Spacing

- 350FLF1 / 1" Filter
- 350FSF1 / 1" Filter
- 350FLF2 / 2" Filter
- 350FSF2 / 2" Filter

1/2" Spacing

- 355FLF1 / 1" Filter
- 355FSF1 / 1" Filter
- 355FLF2 / 2" Filter
- 355FSF2 / 2" Filter

Available 304 Stainless Steel Models:

3/4" Spacing

- 350RLF1-SS / 1" Filter
- 350RSF1-SS / 1" Filter
- 350RLF2-SS / 2" Filter
- 350RSF2-SS / 2" Filter

Products Include:

- 35° Fixed Deflection - Steel and Aluminum
- 45° Fixed Deflection - Stainless Steel
- 1/4-Turn Fastener
- 1- or 2" Filter Frame.
- Available Border Types:
 - #1 - Surface Mount
 - #3 - Lay-In
- Standard Finish - #26 White (Steel and Aluminum Models)
- Standard Finish - #04 Mill (Stainless Steel Models)

350RLF1 / 350RLF2 - Border Type 1(Surface Mount) & Border Type 3 (Lay-in T-Bar)

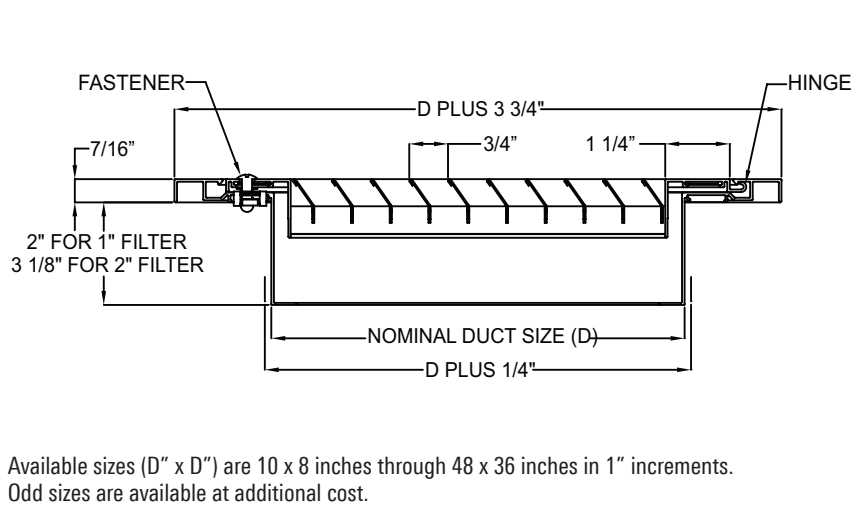

Please refer to page I85 for Hinge Locations

Options and Accessories

Redefine your comfort zone™ | www.titus-hvac.com

Model Number	Type Grille	Type Deflection	Deflection Degrees	Blade Spacing	Border Type	OS	FR	#01	#04	#20	#21	#26	#84	C	DS	IS	FG	PF	PFAP	EQT
301	Stl.-Supply	Single	Adjustable	3/4"	1	Y	Y	Y	Y	Y	Y	Y	Y	Y	Y	Y	Y	Y	N	Y
300	Stl.-Supply	Double	Adjustable	3/4"	1	Y	Y	Y	Y	Y	Y	Y	Y	Y	Y	Y	Y	Y	N	Y
301	Al.-Supply	Single	Adjustable	3/4"	1	Y	Y	Y	Y	Y	Y	Y	Y	Y	Y	Y	Y	Y	N	Y
300	Al.-Supply	Double	Adjustable	3/4"	1	Y	Y	Y	Y	Y	Y	Y	Y	Y	Y	Y	Y	Y	N	Y
301	SS-Supply	Single	Adjustable	3/4"	1	Y	Y	N	Y	N	N	Y	N	N	N	N	Y	Y	N	Y
300	SS-Supply	Double	Adjustable	3/4"	1	Y	Y	N	Y	N	N	Y	N	N	N	N	Y	Y	N	Y
301HD	Stl.-Supply	Single	Adjustable	1/2"	1	Y	Y	Y	Y	Y	Y	Y	Y	N	N	N	Y	Y	N	Y
300HD	Stl.-Supply	Double	Adjustable	1/2"	1	Y	Y	Y	Y	Y	Y	Y	Y	N	N	N	Y	Y	N	Y
301HD	SS-Supply	Single	Adjustable	1/2"	1	Y	Y	Y	Y	Y	Y	Y	Y	N	N	N	Y	Y	N	Y
300HD	SS-Supply	Double	Adjustable	1/2"	1	Y	Y	Y	Y	Y	Y	Y	Y	N	N	N	Y	Y	N	Y

Model Number	Type Grille	Type Deflection	Deflection Degrees	Blade Spacing	Border Type	OS	FR	#01	#04	#20	#21	#26	#84	C	DS	IS	FG	PF	PFAP	EQT
350	Stl.-Return	Single	0/35	3/4"	1	Y	Y	Y	Y	Y	Y	Y	Y	Y	Y	Y	Y	Y	N	Y
350	Al.-Return	Single	0/35	3/4"	1	Y	Y	Y	Y	Y	Y	Y	Y	Y	Y	Y	Y	Y	N	Y
350	SS-Return	Single	0/45	3/4"	1	Y	Y	N	Y	N	N	Y	N	N	N	N	Y	Y	N	Y
355	Stl.-Return	Single	0/35	1/2"	1	Y	Y	Y	Y	Y	Y	Y	Y	N	Y	Y	Y	Y	N	Y
355	Al.-Return	Single	0/35	1/2"	1	Y	Y	Y	Y	Y	Y	Y	Y	N	Y	Y	Y	Y	N	Y
350RF	Stl. Filter Return	Single	35	3/4"	1	N	N	Y	Y	Y	Y	Y	Y	Y	N	N	Y	Y	N	Y
350RF	Stl. Filter Return	Single	35	1/2"	1	N	N	Y	Y	Y	Y	Y	Y	Y	N	N	Y	Y	N	Y
350FF	Al-Filter Return	Single	35	3/4"	1	N	N	Y	Y	Y	Y	Y	Y	Y	N	N	Y	Y	N	Y
350FF	Al-Filter Return	Single	35	1/2"	1	N	N	Y	Y	Y	Y	Y	Y	Y	N	N	Y	Y	N	Y
350RF	SS Filter Return	Single	45	3/4"	1	N	N	N	Y	N	N	Y	N	N	N	N	Y	Y	N	Y
350	Stl.-Return	Single	0/35	3/4"	3	N	Y	Y	Y	Y	Y	Y	Y	N	Y	Y	N	N	N	Y
355	Stl.-Return	Single	0/35	1/2"	3	N	Y	Y	Y	Y	Y	Y	Y	N	Y	Y	N	N	N	Y
350RF	Stl. Filter Return	Single	35	3/4"	3	N	N	Y	Y	Y	Y	Y	Y	Y	N	N	N	N	N	Y
350RF	Stl. Filter Return	Single	35	1/2"	3	N	N	Y	Y	Y	Y	Y	Y	Y	N	N	N	N	N	Y
350	Al.-Return	Single	0/35	3/4"	3	N	Y	Y	Y	Y	Y	Y	Y	N	Y	Y	N	N	N	Y
355	Al.-Return	Single	0/35	1/2"	3	N	Y	Y	Y	Y	Y	Y	Y	N	Y	Y	N	N	N	Y
350FF	Al-Filter Return	Single	35	3/4"	3	N	N	Y	Y	Y	Y	Y	Y	Y	N	N	N	N	N	Y
350FF	Al-Filter Return	Single	35	1/2"	3	N	N	Y	Y	Y	Y	Y	Y	Y	N	N	N	N	N	Y
350	Stl.-Return	Single	0/35	3/4"	2	N	Y	Y	Y	Y	Y	Y	Y	N	Y	Y	N	N	N	Y
355	Stl.-Return	Single	0/35	1/2"	2	N	Y	Y	Y	Y	Y	Y	Y	N	Y	Y	N	N	N	Y
350	Al.-Return	Single	0/35	3/4"	2	N	Y	Y	Y	Y	Y	Y	Y	N	Y	Y	N	N	N	Y
355	Al.-Return	Single	0/35	1/2"	2	N	Y	Y	Y	Y	Y	Y	Y	N	Y	Y	N	N	N	Y
350	Stl.-Return	Single	0/35	3/4"	4	N	Y	Y	Y	Y	Y	Y	Y	N	Y	Y	N	N	N	Y
355	Stl.-Return	Single	0/35	1/2"	4	N	Y	Y	Y	Y	Y	Y	Y	N	Y	Y	N	N	N	Y
350	Al.-Return	Single	0/35	3/4"	4	N	Y	Y	Y	Y	Y	Y	Y	N	Y	Y	N	N	N	Y
355	Al.-Return	Single	0/35	1/2"	4	N	Y	Y	Y	Y	Y	Y	Y	N	Y	Y	N	N	N	Y
AG-15	Stl.-Damper	---	---	---	---	Y	Y	N	Y	N	N	Y	Y	---	---	---	---	---	---	---
AG-15-AA	Al.-Damper	---	---	---	---	Y	Y	N	Y	N	N	Y	Y	---	---	---	---	---	---	---
AG-15-SS	SS-Damper	---	---	---	---	Y	Y	N	Y	N	N	N	N	---	---	---	---	---	---	---

Caution: All options are not available in all combinations. Check with your Titus representative for details. Titus reserves the right to discontinue or add options at any time without notice.

SERIES FINISHES, OPTIONS AND ACCESSORIES

Finishes:

- #01 Aluminum Colored Paint
- #04 Mill Finish
- #20 Envirotherm Color To Match Sample*
- #21 Envirothane Color To Match Sample*
- #25 Off White*
- #26 White (standard on most models)
- #84 Black*

Options & Accessories:

- OS Oversize
- FR Fractional Size
- C Concealed Fasteners
- DS Debris Screen 1/4" Square Mesh
- Galvanized Steel Screen
- IS Insect Screen 1/16" Square Mesh
- Galvanized Steel Screen
- FG Foam Gasket On Back Side of Border
- PF Steel Plaster Frame
- PFA Aluminum Plaster Frame
- PF-SS Stainless Steel Plaster Frame
- EQT Earthquake Tab For Safety Wiring to Support Structure

Note: An asterisk (*) indicates additional cost
Concealed mounting not available with damper

BORDER TYPES

BORDER TYPE 2 SNAP-IN (PANEL MOUNTED)

Available Module Size
24 x 24 inches

BORDER TYPE 3 LAY-IN (PANEL MOUNTED)

Available Module Sizes
12 x 12 inches 24 x 12 inches
36 x 12 inches 48 x 12 inches
24 x 24 inches 36 x 24 inches
48 x 24 inches

BORDER TYPE 4 SPLINE (PANEL MOUNTED)

Available Module Sizes
24 x 24 inches

BORDER TYPE NT NARROW TEE (PANEL MOUNTED)

Available Module Sizes
24 x 12 inches 24 x 24 inches

Note: Filter grilles not available in all module sizes

ACCESSORIES

TYPE A FASTENING - SURFACE MOUNT

- Standard For All Border Type
1 Surface Mount Grilles
- Note: For screw hole locations see the chart, "Screw Hole Location Chart"

TYPE C FASTENING - CONCEALED MOUNTING

- Available on Most Models
with Border Type 1

Snap-In

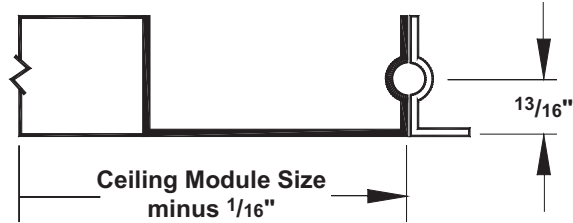

Note: Maximum grille area is module size minus 4 inches

Lay-In (Panel Mounted)

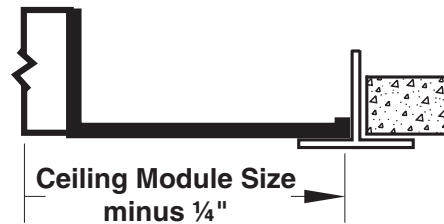

Note: Maximum grille area is module size minus 4 inches

Spline (Panel Mounted)

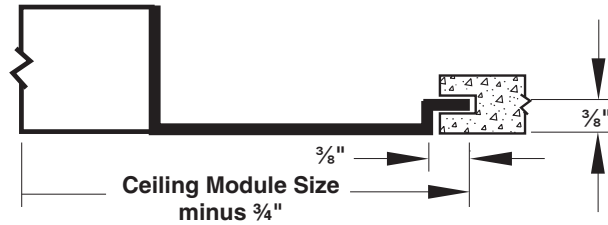

Note: Maximum grille area is module size minus 4 inches

Narrow Tee (Panel Mounted)

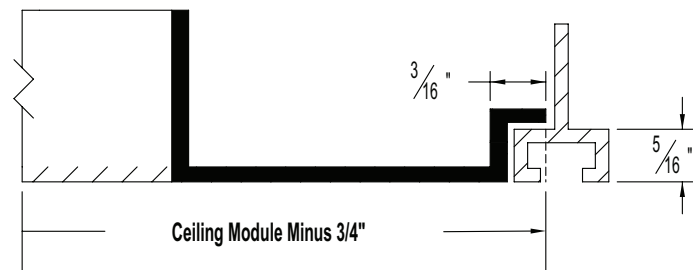

Type A - External Screw

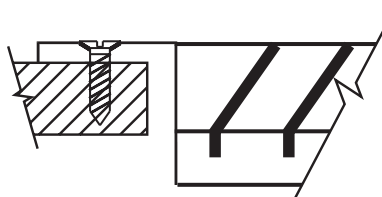

Type C - Concealed Screw

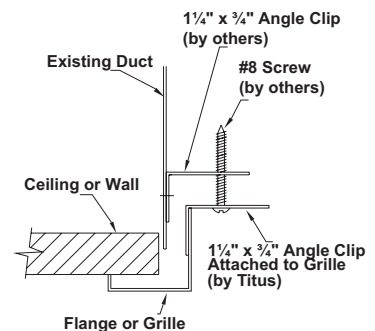

Oversize Grille Construction

300 / 350 grilles

300/350 SERIES
FOR DUCTS OR OPENINGS LARGER THAN 48 INCHES

Redefine your comfort zone™ | www.titus-hvac.com

Joining With Aluminum Mullions or Alignment Tabs

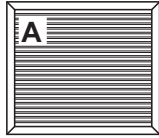

8"-48" Wide

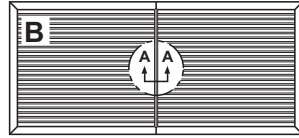

49"-96" Wide

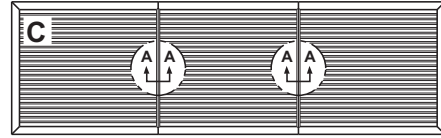

97"-144" Wide

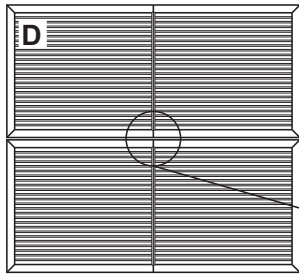

49"-96" Wide and
49"-96" High

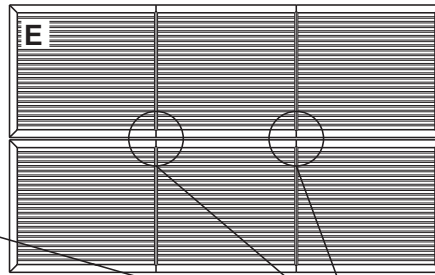

97"-144" Wide and
49"-96" High

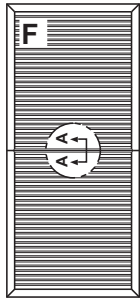

6-48" Wide and
49"-96" High

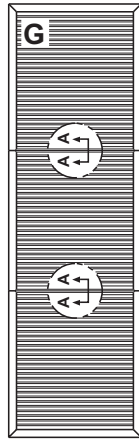

6-48" Wide and
97"-144" High

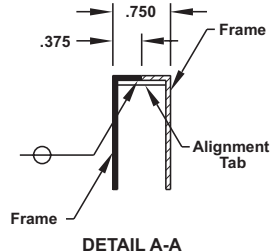
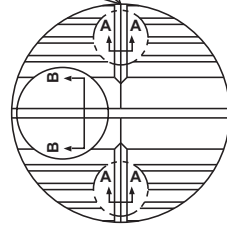

DETAIL A-A

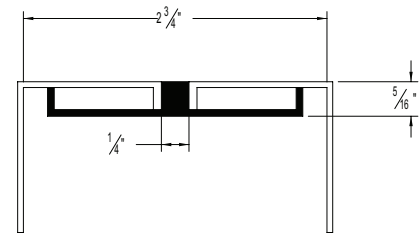

DETAIL B-B

H

OVERSIZE GRILLE CONSTRUCTION

Screw Hole Location Chart

300 / 350 grilles

For use with 300/350 Grilles up to 48" x 36"
(not for use with filter grilles)

HOW TO USE THESE CHARTS

1. Determine desired grille size
2. Find the grille size in Grille Size Chart
3. Use the Grille Size Chart to select the proper diagram number. The number corresponds to the diagrams in the Screw Hole Layout Diagrams 1-14.

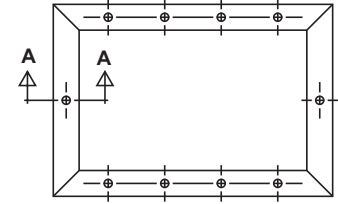

Grille Size Chart

WIDTH	LENGTH																					
	4	6	8	10	12	14	16	18	20	22	24	26	28	30	32	34	36	38	40	42	44	46
4	A				B				C													
6	A				B				C													
8	A				B				C													
10	A				B				C													
12	A				B				C													
14	A				B				C													
16	A				B				C													
18	A				B				C													
20	A				B				C													
22	A				B				C													
24	A				B				C													
26	A				B				C													
28	A				B				C													
30	A				B				C													
32	A				B				C													
34	A				B				C													
36	A				B				C													
38	A				B				C													
40	A				B				C													
42	A				B				C													
44	A				B				C													
46	A				B				C													
48	A				B				C													

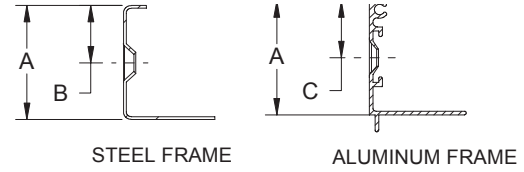

Frame Width	1/2	3/4	1	1 1/8	1.25 and Greater
A					
B	-	-	.44	.44	.63
C	.25	.34	.5	-	

Screw Layout Diagrams 1 - 14

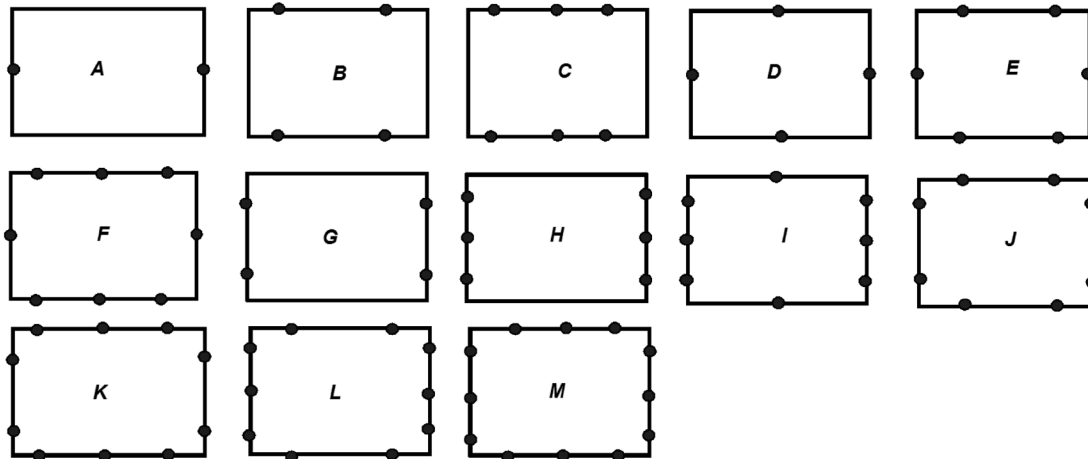

Note 1: This chart provides general information concerning location of screw holes. Screw hole location is subject to change without notice. Titus does not recommend pre-drilling mounting surfaces for screws. Use the grille as a template. This chart applies to border type 1 only.

Note 2: All holes are located 5/8" from outside edge. Location of hole according to number required. (One Hole) Located midway between ends. (Two Holes) Locate each hole 3 inches from each end. (Three Holes) Locate one hole 3 inches from each end and center the third hole.

